



NATIONAL TEST REPORT
(BS 6180 : 2011)

EASY GLASS[®] PRO

F-PROFILE

MOD.6909

FIXED "SAFETY WEDGES SYSTEM", H= 1100MM
FIXED "SAFETY WEDGES SYSTEM", H= 1200MM

ADJUSTABLE "SAFETY WEDGES SYSTEM", H= 1100MM
ADJUSTABLE "SAFETY WEDGES SYSTEM", H= 1200MM

TEST REPORT

Lucideon Reference: 143646 (QT-31643/1/SL)/Ref. 3/CR1

Project Title: Testinfg of Q-railing Europe Glass Balustrade System to BS 6180:2011 - Easy Glass Pro-F Top Mount Fixed

Client: Q-railing Europe GmbH & Co.KG
Marie-Curie-Strasse 8-14
Emmerich am Rhein
D-46446
Germany

For the Attention of: Mr Samuel Hanna

Author(s): Miss Lisa Cobden

Report Date: 11 November, 2014

Purchase Order No.: N/A

Work Location: Lucideon UK

This report supersedes the report issued on 29.08.14.



Mr Dave Dix
Consultancy Team
Reviewer



Miss Lisa Cobden
Consultancy Team
Project Manager

CONTENTS

	Page
1 INTRODUCTION	3
2 TEST SAMPLES	3
3 TEST PROGRAMME	3
4 TEST METHOD	3
5 RESULTS	4
TABLES	5-6
PLATE	7
CHART	8

APPENDIX: Figures

LSC/LMP/N14TRE48
11.11.14

1 INTRODUCTION

Lucideon were commissioned by the client, Q-railing Europe GmbH and Co KG, to carry out load testing in accordance with BS 6180:2011 Barriers in and about buildings, to allow their balustrade system to be classified for use in accordance with the Code of Practice included within the standard.

The testing was carried out at Q-railing Europe GmbH and Co KG's facilities at 8-14 Marie-Curie Straße 46446 Emmerich am Rhein Germany.

This report summarises the test results obtained during the test programme and does not provide interpretation of those results.

2 TEST SAMPLES

The aluminium channel tested was designated as Easy Glass Pro-F Top Mount Fixed. The system is shown in Figure 1.

The channel was installed by Q-railing personnel.

3 TEST PROGRAMME

A horizontal line load was applied to the aluminium channel with the following glass types installed:

- Laminated VSG Glass 16.76 mm – size (w x h):1000 mm x 1100 mm.
- Laminated VSG Glass 21.52 mm – size (w x h):1000 mm x 1100 mm.
- Laminated Sentry Glass 21.52 mm – size (w x h): 1000 mm x 1100 mm.
- Monolithic ESG Glass 19 mm – size (w x h): 1000 mm x 1100 mm.
- Monolithic ESG Glass 15 mm – size (w x h): 1000 mm x 1100 mm.

4 TEST METHOD

The channel was bolted to the top of a concrete block, which was fixed to the floor of the test facility. The 1.0 m length of channel was bolted to the block at 200 mm centres by the client using the appropriate fixings.

The appropriate thickness glass panel was fitted into the channel using the 'Safety Wedge' fixing clips at four clips per metre such that the plastic clip was to the inside face of the glass (see Figures 2 and 3).

A horizontal imposed line load was applied to the glass at a height of 1.1 m above the datum level of the floor and the deflection measured at the top central point of the panel 1.1 m above the datum level of the floor. The load was applied via a hydraulic ram and the deflection measured using a linear voltage displacement transducer (see Plate 1).

5 RESULTS

The test was carried out in accordance with the guidance given in BS 6180 Barriers in and about buildings – Code of Practice. The standard states that the maximum allowable deflection for a free standing glass protective barrier panel is 25 mm.

Table 2 of BS 6180 Barriers in and about buildings – Code of Practice categorises parapets, barriers and balustrades for areas of use depending on the loads they have achieved under testing.

The loads achieved by the Q-railing Europe GmbH and Co KG glazing system tested under horizontal imposed line load to the maximum deflection of 25 mm are given in Table 1.

All figures quoted in Table 1 contain no safety factors and are direct loads as achieved by the system under test conditions.

Table 2 summarises the suitability of the tested systems in accordance with Table 2 of BS 6180:2011.

NOTE: The results given in this report apply only to the samples that have been tested.

END OF REPORT

Table 1: Summary of Performance of Q-railing Europe GmbH and Co. KG Balustrade System Tested under Horizontal Imposed Line Load

Base Rail	Glass	Imposed Line Load at 25 mm Deflection (kN/m)	Working Line Load for System (kN/m)	Deflection at Working Line Load for System (mm)
System	Laminated VSG Glass 16.76 mm	0.74	0.74	25.00
	Laminated VSG Glass 21.52 mm	1.05	0.74	16.28
	Laminated Sentry Glass 21.52 mm	1.62	1.50	21.92
	Monolithic ESG 19 mm	1.60	1.50	22.97
	Monolithic ESG 15 mm	1.14	0.74	15.47

Table 2: Summary of Suitability of Q-railing Europe Systems in Accordance with Table 2 of BS 6180:2011

Type of Occupancy for Part of the Building	Examples of Specific Use	Horizontal Uniformly Distributed Line Load (kN/m)	Easy Glass Pro-F Top Mount Fixed				
			16.76 mm	21.52 mm	Sentry 21.52 mm	19 mm	15 mm
Domestic and residential activities	(i) all areas within or serving exclusively one single family dwelling including stairs, landings, etc but excluding external balconies and edges of roofs	0.36	✓	✓	✓	✓	✓
	(ii) other residential, i.e. houses of multiple occupancy and balconies, including Juliette balconies and edges of roofs in single family dwellings	0.74	✓	✓	✓	✓	✓
Offices and work areas not included elsewhere, including storage areas	(iii) light access stairs and gangways not more than 600 mm wide	0.22	✓	✓	✓	✓	✓
	(iv) light pedestrian traffic routes in industrial and storage buildings except designated escape routes	0.36	✓	✓	✓	✓	✓
	(v) areas not susceptible to overcrowding in office and institutional buildings, also industrial and storage buildings except as given above	0.74	✓	✓	✓	✓	✓

Type of Occupancy for Part of the Building	Examples of Specific Use	Horizontal Uniformly Distributed Line Load (kN/m)	Easy Glass Pro-F Top Mount Fixed				
			16.76 mm	21.52 mm	Sentry 21.52 mm	19 mm	15 mm
Areas where people might congregate	(vi) areas having fixed seating within 530 mm of the barrier, balustrade or parapet	1.50	X	X	✓	✓	X
Areas with tables or fixed seating	(vii) restaurants and bars	1.50	X	X	✓	✓	X
Areas without obstacles for moving people and not susceptible to overcrowding	(viii) stairs, landings corridors ramps	0.74	✓	✓	✓	✓	✓
	(ix) external balconies including Juliette balconies and edges of roofs; footways and pavements within building cartilage adjacent to basement/sunken areas	0.74	✓	✓	✓	✓	✓
Areas susceptible to overcrowding	(x) footways or pavements less than 3 m wide adjacent to sunken areas	1.50	X	X	✓	✓	X
	(xi) theatres, cinemas, discotheques, bars, auditoria, shopping malls, assembly areas, studios; footways or pavements greater than 3 m wide adjacent to sunken areas	3.00	X	X	X	X	X
	(xii) grandstands and stadia	(Note 1)	-	-	-	-	-
Retail areas	(xiii) all retail areas including public areas of banks/building societies or betting shops	1.50	X	X	✓	✓	X
Vehicular	(xiv) pedestrian areas in car parks, including stairs, landings, ramps, edges of internal floors, footways, edges of roofs	1.50 (Note 2)	X	X	✓	✓	X
	(xv) horizontal loads imposed by vehicles	(Note 2)	-	-	-	-	-

Note 1 – See requirements of the appropriate certifying authority

Note 2 – Clause 8.1.1 of BS 6180:2011 states that “glass should not be used for vehicle protection barriers”



Plate 1: Generic Test Arrangement

Chart 1: Load Versus Deflection Curves for Q-railing Easy Glass Pro-F Top Mount Fixed

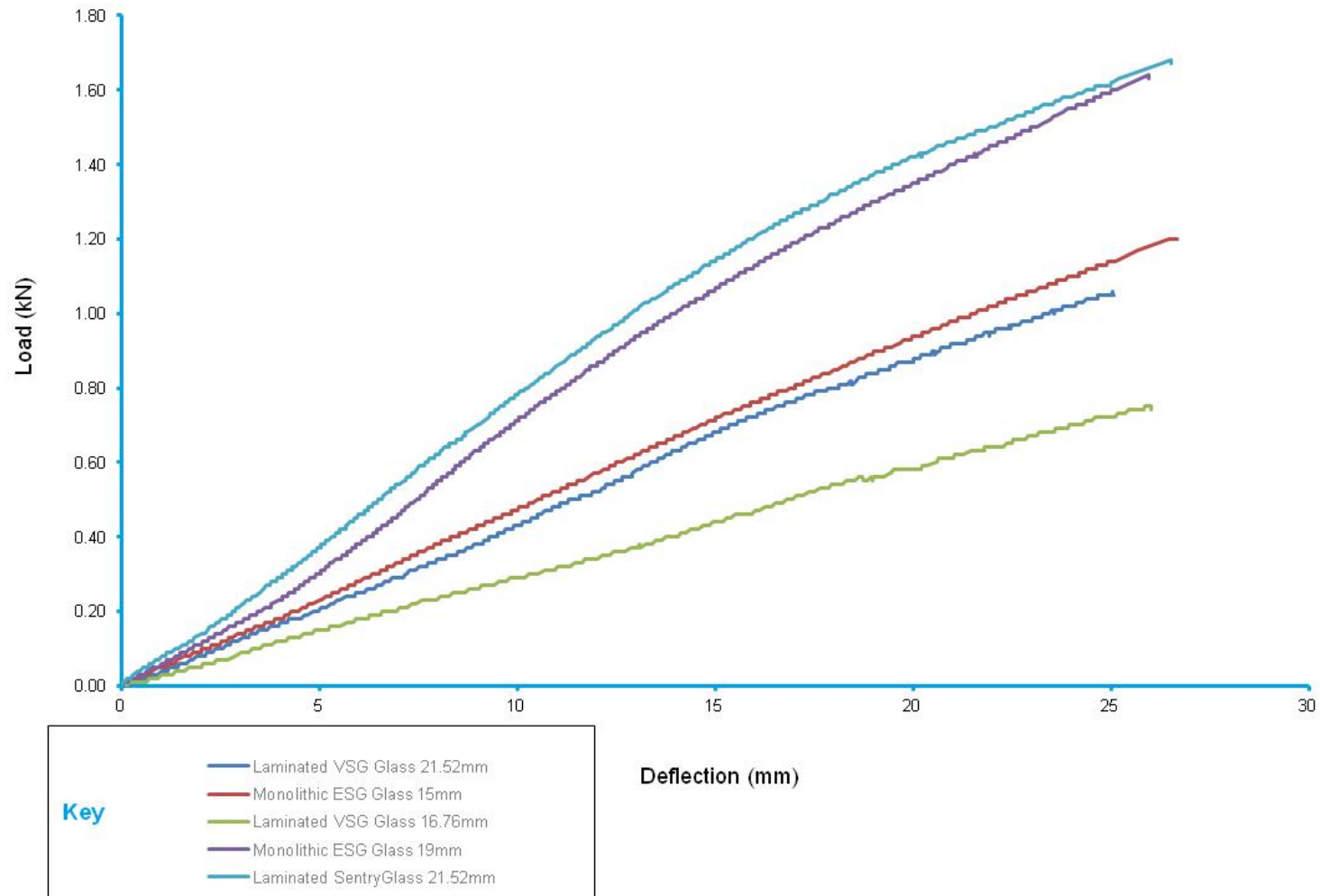

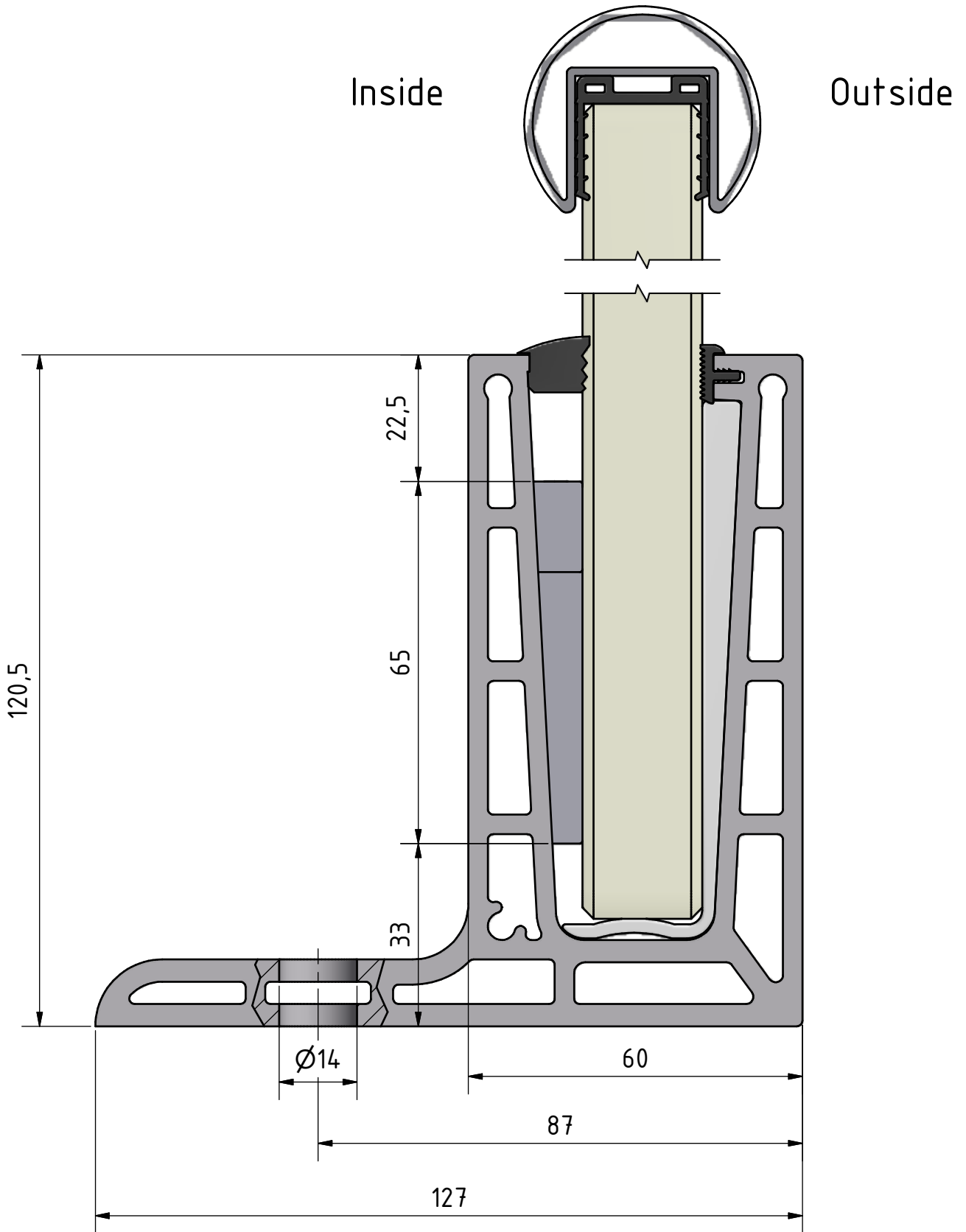

Inlay and Wedge 4 per meter

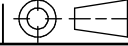
		Scale: 1 : 1	Weight:		Rev.No.: 0
		Material:			
<small>THIS DRAWING IS PROPERTY OF Q-RAILING EUROPE GmbH & Co KG ALL RIGHTS RESERVED. It may not be submitted for perusal to third parties, either whole nor partly, unless granted. It is not permitted to alter this drawing unauthorised, in any way.</small>		Finish:			
<small>THIS DRAWING IS PROPERTY OF Q-RAILING EUROPE GmbH & Co KG ALL RIGHTS RESERVED. It may not be submitted for perusal to third parties, either whole nor partly, unless granted. It is not permitted to alter this drawing unauthorised, in any way.</small>		Product line:			
		EASY GLASS SYSTEM			
		Description:			
		Pro F Mount, Fixed			
		Drawing no.:			Sheet:
		16690950018			1 / 1
					A4

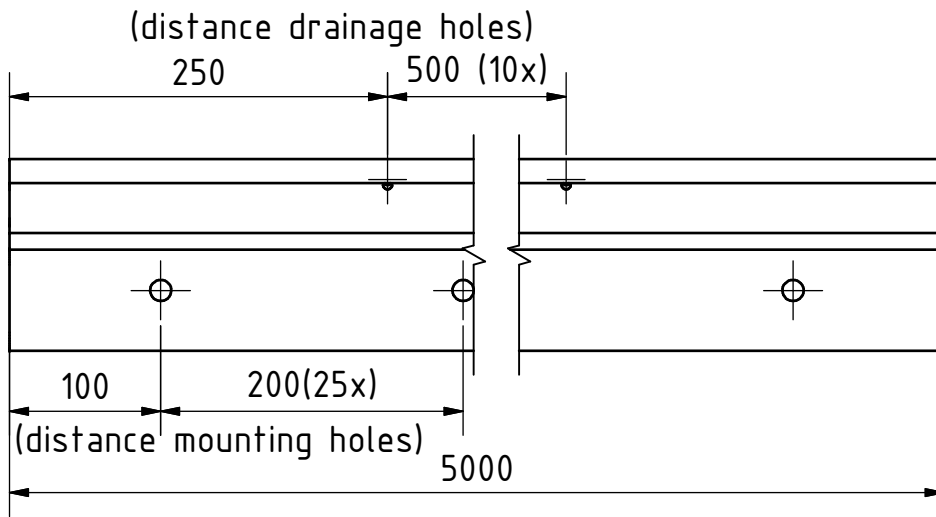

3D view

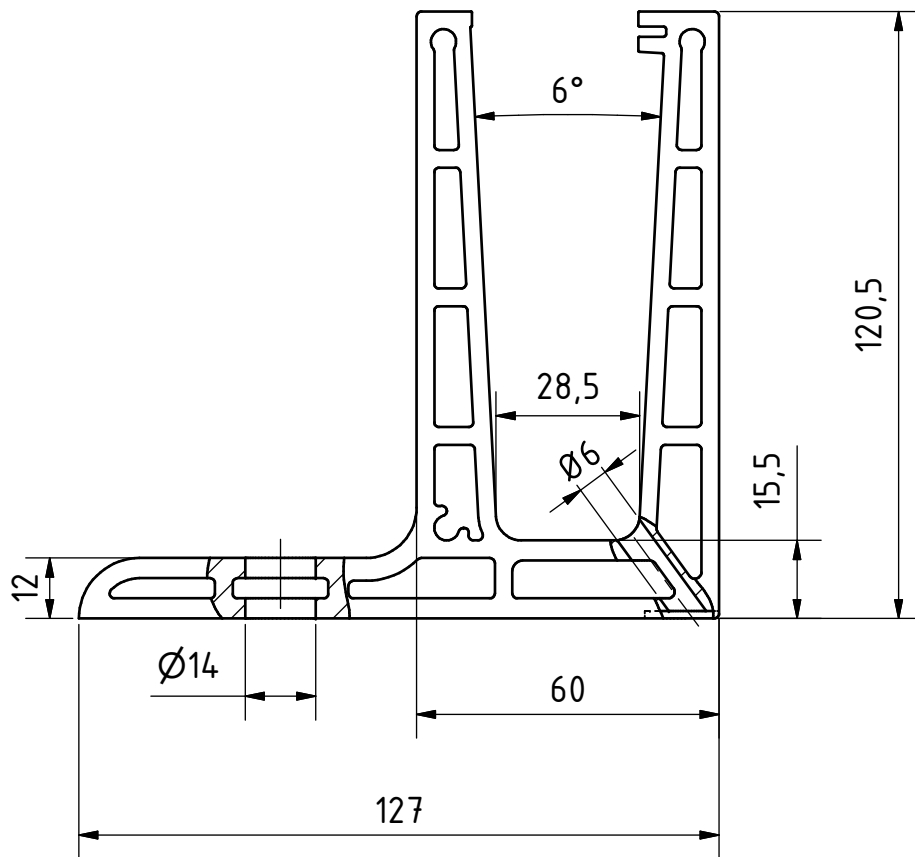
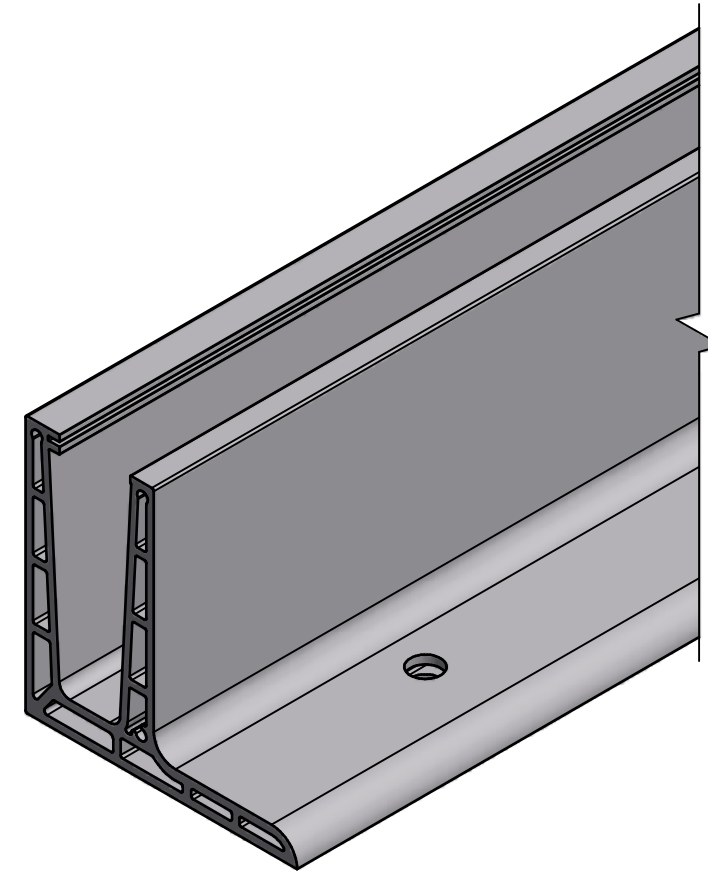

		Scale: 1 : 1,5	Weight: 38 kg		Rev.No.: 0									
		Material: EN AW-6063 T6		Finish: sample no ~18										
<small>THIS DRAWING IS PROPERTY OF Q-RAILING EUROPE GmbH & Co KG ALL RIGHTS RESERVED. It may not be submitted for perusal to third parties, either whole nor partly, unless granted. It is not permitted to alter this drawing unauthorised, in any way.</small>		Product line: Easy Glass Pro												
<table border="1"> <thead> <tr> <th></th> <th>Date</th> <th>Name</th> </tr> </thead> <tbody> <tr> <td>Drawn</td> <td>31.01.2014</td> <td>YPE</td> </tr> <tr> <td>Checked</td> <td>13.05.2014</td> <td>TRR</td> </tr> </tbody> </table>			Date	Name	Drawn	31.01.2014	YPE	Checked	13.05.2014	TRR	Description: Base Shoe Top F			
	Date	Name												
Drawn	31.01.2014	YPE												
Checked	13.05.2014	TRR												
Drawing no.: CD-16690950018				Sheet: 1 / 1										
				A4										

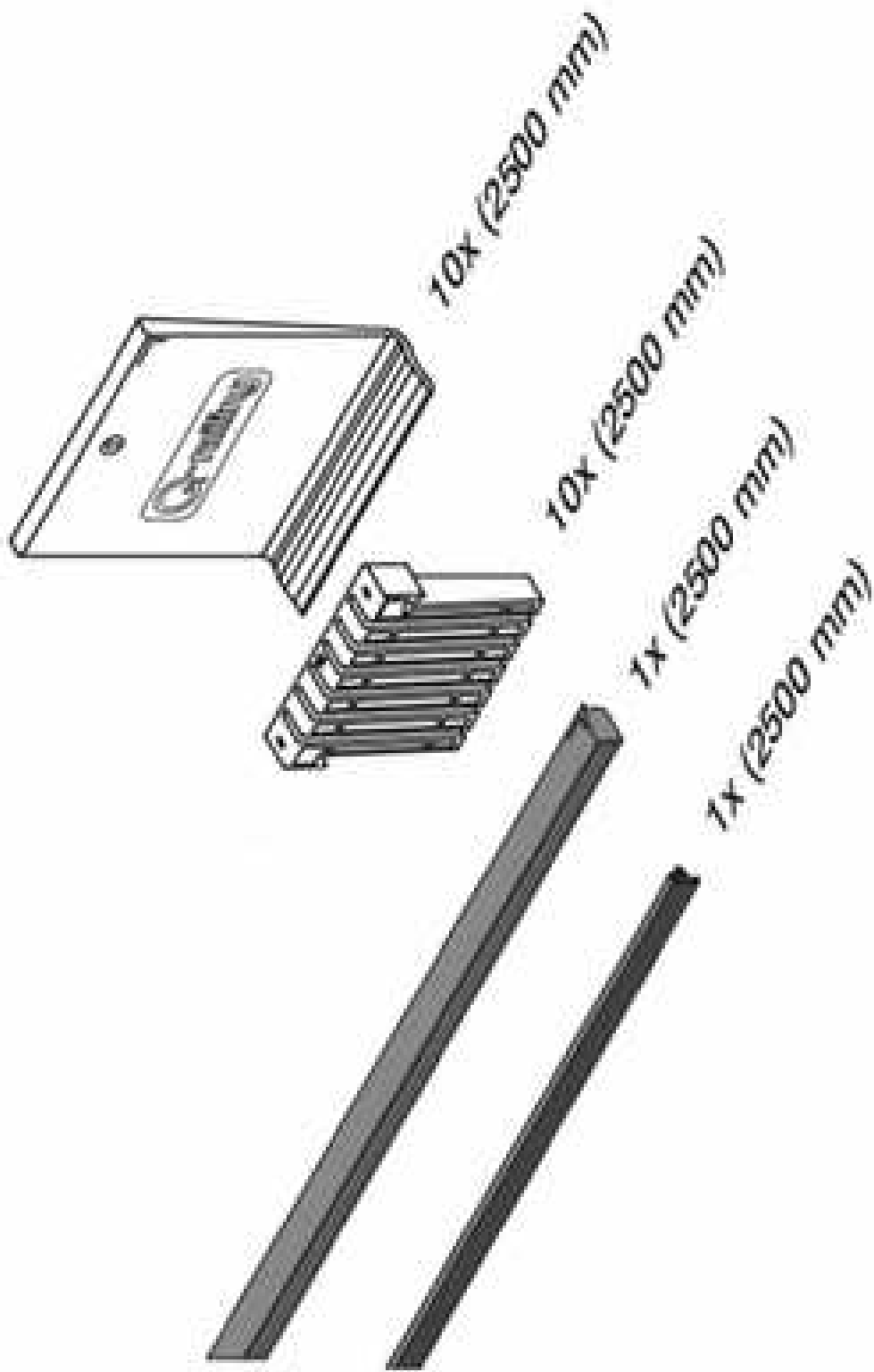

TEST REPORT

Lucideon Reference: 143646 (QT-31643/1/SL)/Ref. 4/CR1

Project Title: Testing of Q-railing Europe Glass Balustrade System to BS 6180:2011 - Easy Glass Pro-F Top Mount Fixed at Horizontal Line Load 1200 mm

Client: Q-railing Europe GmbH & Co.KG
Marie-Curie-Strasse 8-14
Emmerich am Rhein
D-46446
Germany

For the Attention of: Mr Samuel Hanna

Author(s): Miss Lisa Cobden

Report Date: 11 November, 2014

Purchase Order No.: N/A

Work Location: Lucideon UK

This report supersedes the report issued on 29.08.14.



Mr Dave Dix
Consultancy Team
Reviewer



Miss Lisa Cobden
Consultancy Team
Project Manager

CONTENTS

	Page
1 INTRODUCTION	3
2 TEST SAMPLES	3
3 TEST PROGRAMME	3
4 TEST METHOD	3
5 RESULTS	4
TABLES	5-6
PLATE	7
CHART	8

APPENDIX: Figures

LSC/LMP/N14TRE49
11.11.14

1 INTRODUCTION

Lucideon were commissioned by the client, Q-railing Europe GmbH and Co KG, to carry out load testing based on that detailed in BS 6180:2011 Barriers in and about buildings. This was to allow their balustrade system to be classified for use in accordance with the Code of Practice included within the standard. The test method deviated from the standard such that the horizontal imposed line load was applied to the glass at a height of 1.2 m above the datum level of the floor in comparison to 1.1 m stated in the standard. Deflection of the glass panel was measured at the top central point and was also recorded at 1.2 m above the datum level of the floor.

The testing was carried out at Q-railing Europe GmbH and Co KG's facilities at 8-14 Marie-Curie Straße 46446 Emmerich am Rhein Germany.

This report summarises the test results obtained during the test programme and does not provide interpretation of those results.

2 TEST SAMPLES

The aluminium channel tested was designated as Easy Glass Pro-F Top Mount Fixed. The system is shown in Figure 1.

The channel was installed by Q-railing personnel.

3 TEST PROGRAMME

A horizontal line load was applied to the aluminium channel with the following glass types installed:

- Laminated VSG Glass 21.52 mm – size (w x h): 1000 mm x 1200 mm.
- Laminated Sentry Glass 21.52 mm – size (w x h): 1000 mm x 1300 mm.
- Monolithic ESG Glass 19 mm – size (w x h): 1000 mm x 1200 mm.
- Monolithic ESG Glass 15 mm – size (w x h): 1000 mm x 1200 mm.

4 TEST METHOD

The channel was bolted to the top of a concrete block, which was fixed to the floor of the test facility. The 1.0 m length of channel was bolted to the block at 200 mm centres by the client using the appropriate fixings.

The appropriate thickness glass panel was fitted into the channel using the 'Safety Wedge' fixing clips at four clips per metre such that the plastic clip was to the inside face of the glass (see Figures 2 and 3).

A horizontal imposed line load was applied to the glass at a height of 1.2 m above the datum level of the floor and the deflection measured at the top central point of the panel 1.2 m above the datum level of the floor. The load was applied via a hydraulic ram and the deflection measured using a linear voltage displacement transducer (see Plate 1).

5 RESULTS

The test was carried out in accordance with the guidance given in BS 6180 Barriers in and about buildings – Code of Practice. The standard states that the maximum allowable deflection for a free standing glass protective barrier panel is 25 mm.

Table 2 of BS 6180 Barriers in and about buildings – Code of Practice categorises parapets, barriers and balustrades for areas of use depending on the loads they have achieved under testing.

The loads achieved by the Q-railing Europe GmbH and Co KG glazing system tested under horizontal imposed line load to the maximum deflection of 25 mm are given in Table 1.

All figures quoted in Table 1 contain no safety factors and are direct loads as achieved by the system under test conditions.

Table 2 summarises the suitability of the tested systems in accordance with Table 2 of BS 6180:2011.

NOTE: The results given in this report apply only to the samples that have been tested.

END OF REPORT

Table 1: Summary of Performance of Q-railing Europe GmbH and Co KG Balustrade System Tested under Horizontal Imposed Line Load

Base Rail	Glass	Imposed Line Load at 25 mm Deflection (kN/m)	Working Line Load for System (kN/m)	Deflection at Working Line Load for System (mm)
System	Laminated VSG Glass 21.52 mm	0.94	0.74	19.74
	Laminated Sentry Glass 21.52 mm	1.62	1.50	21.92
	Monolithic ESG 19 mm	1.40	0.74	11.60
	Monolithic ESG 15 mm	1.03	0.74	17.97

Table 2: Summary of Suitability of Q-railing Europe Systems in Accordance with Table 2 of BS 6180:2011

Type of Occupancy for Part of the Building	Examples of Specific Use	Horizontal Uniformly Distributed Line Load (kN/m)	Easy Glass Pro-F Top Mount Fixed			
			21.52 mm	Sentry 21.52 mm	19 mm	15 mm
Domestic and residential activities	(i) all areas within or serving exclusively one single family dwelling including stairs, landings, etc but excluding external balconies and edges of roofs	0.36	✓	✓	✓	✓
	(ii) other residential, i.e. houses of multiple occupancy and balconies, including Juliette balconies and edges of roofs in single family dwellings	0.74	✓	✓	✓	✓
Offices and work areas not included elsewhere, including storage areas	(iii) light access stairs and gangways not more than 600 mm wide	0.22	✓	✓	✓	✓
	(iv) light pedestrian traffic routes in industrial and storage buildings except designated escape routes	0.36	✓	✓	✓	✓
	(v) areas not susceptible to overcrowding in office and institutional buildings, also industrial and storage buildings except as given above	0.74	✓	✓	✓	✓
Areas where people might congregate	(vi) areas having fixed seating within 530 mm of the barrier, balustrade or parapet	1.50	X	✓	X	X

Type of Occupancy for Part of the Building	Examples of Specific Use	Horizontal Uniformly Distributed Line Load (kN/m)	Easy Glass Pro-F Top Mount Fixed			
			21.52 mm	Sentry 21.52 mm	19 mm	15 mm
Areas with tables or fixed seating	(vii) restaurants and bars	1.50	X	✓	X	X
Areas without obstacles for moving people and not susceptible to overcrowding	(viii) stairs, landings corridors ramps	0.74	✓	✓	✓	✓
	(ix) external balconies including Juliette balconies and edges of roofs; footways and pavements within building cartilage adjacent to basement/sunken areas	0.74	✓	✓	✓	✓
Areas susceptible to overcrowding	(x) footways or pavements less than 3 m wide adjacent to sunken areas	1.50	X	✓	X	X
	(xi) theatres, cinemas, discotheques, bars, auditoria, shopping malls, assembly areas, studios; footways or pavements greater than 3 m wide adjacent to sunken areas	3.00	X	X	X	X
	(xii) grandstands and stadia	(Note 1)	-	-	-	-
Retail areas	(xiii) all retail areas including public areas of banks/building societies or betting shops	1.50	X	✓	X	X
Vehicular	(xiv) pedestrian areas in car parks, including stairs, landings, ramps, edges of internal floors, footways, edges of roofs	1.50 (Note 2)	X	✓	X	X
	(xv) horizontal loads imposed by vehicles	(Note 2)	-	-	-	-

Note 1 – See requirements of the appropriate certifying authority

Note 2 – Clause 8.1.1 of BS 6180:2011 states that “glass should not be used for vehicle protection barriers”



Plate 1: Generic Test Arrangement

Chart 1: Load Versus Deflection Curves for Q-railing Easy Glass Pro -F Top Mount Fixed Loaded at 1200 mm

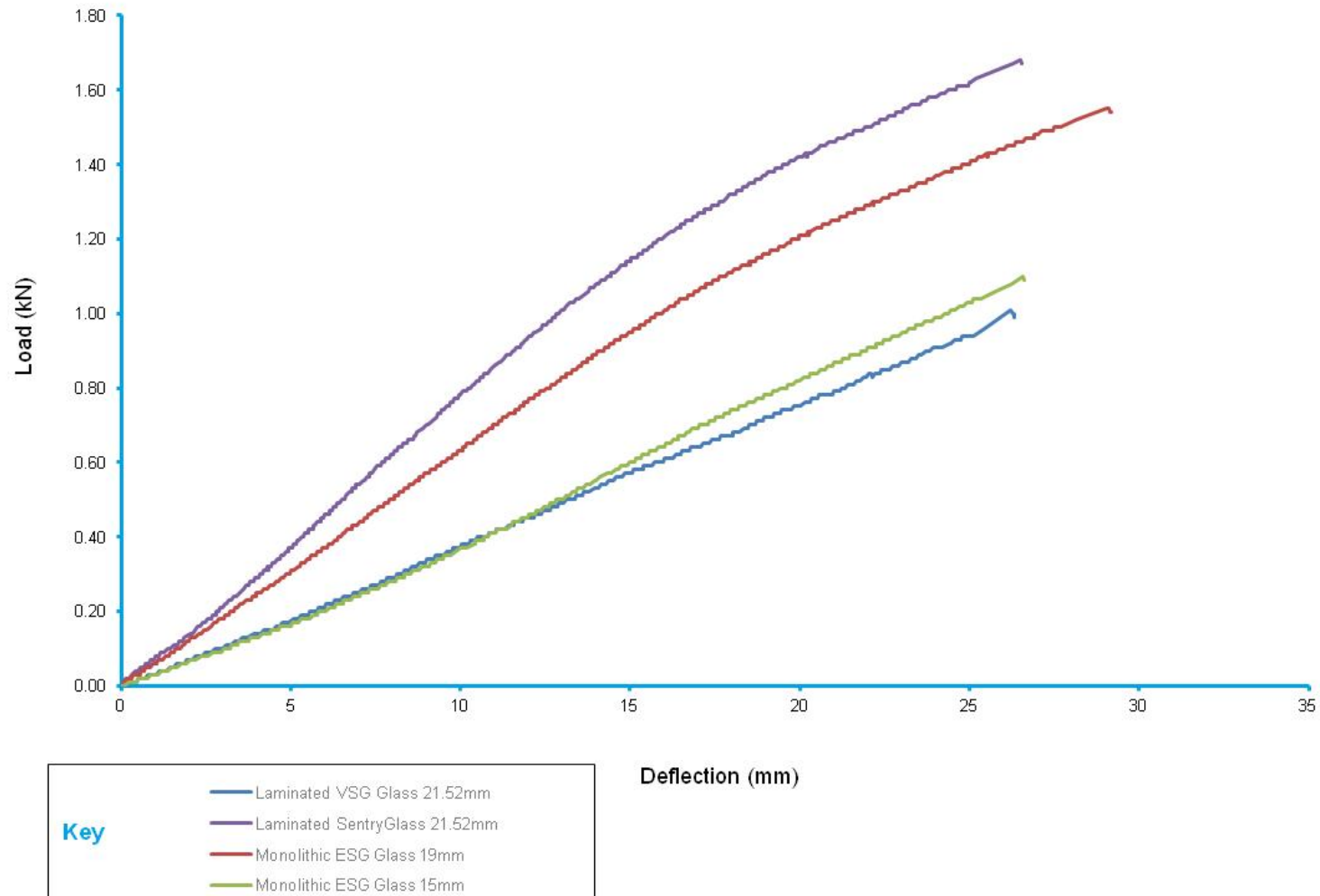

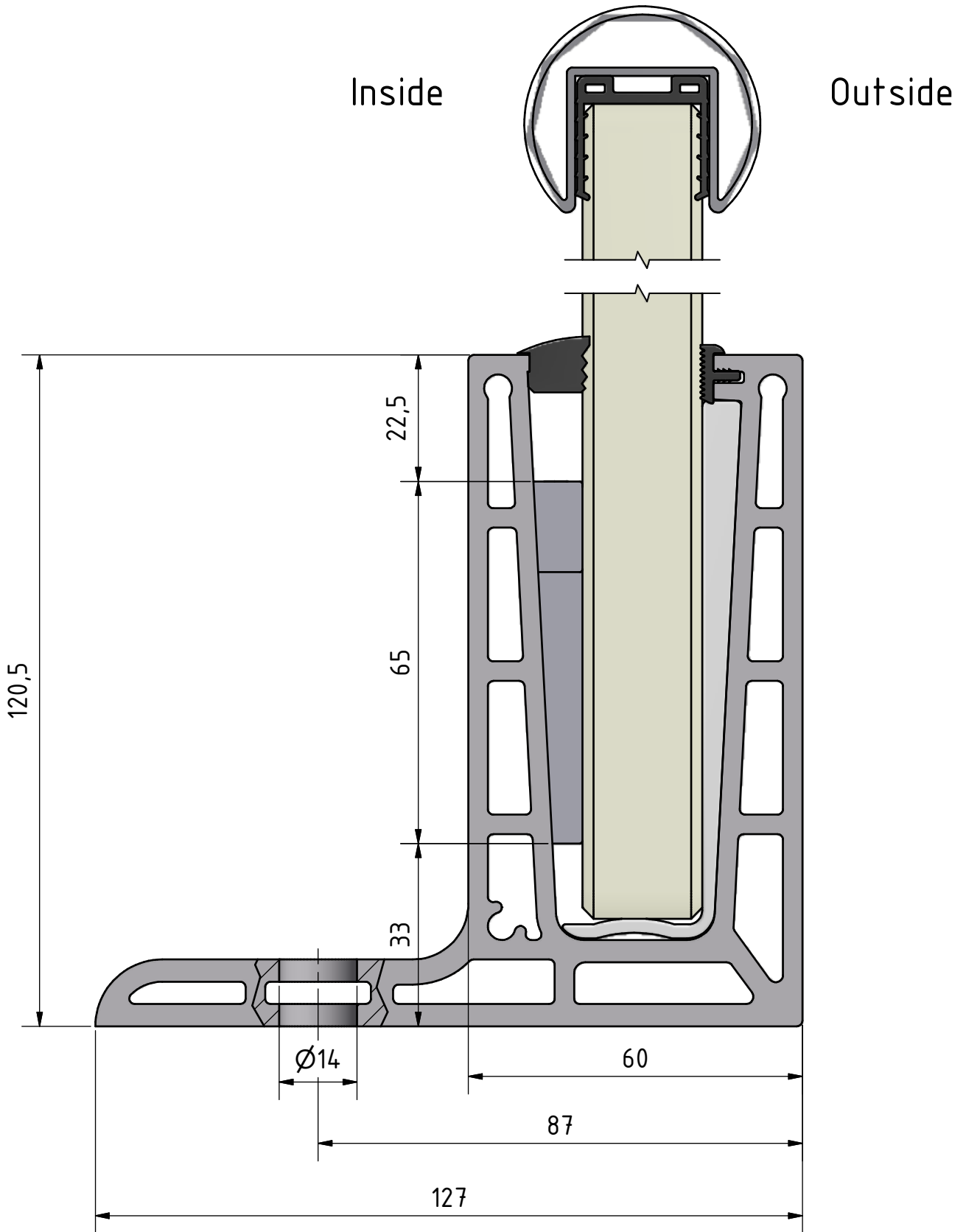

Inlay and Wedge 4 per meter

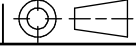
		Scale: 1 : 1	Weight:		Rev.No.: 0
		Material: Finish:			
<small>THIS DRAWING IS PROPERTY OF Q-RAILING EUROPE GmbH & Co KG ALL RIGHTS RESERVED. It may not be submitted for perusal to third parties, either whole nor partly, unless granted. It is not permitted to alter this drawing unauthorised, in any way.</small>		Product line:			
		EASY GLASS SYSTEM			
		Description:			
Drawn	Date	Name	Pro F Mount, Fixed		
Checked	27.01.2014	MBT			
		Drawing no.:			Sheet:
		16690950018			1 / 1
					A4

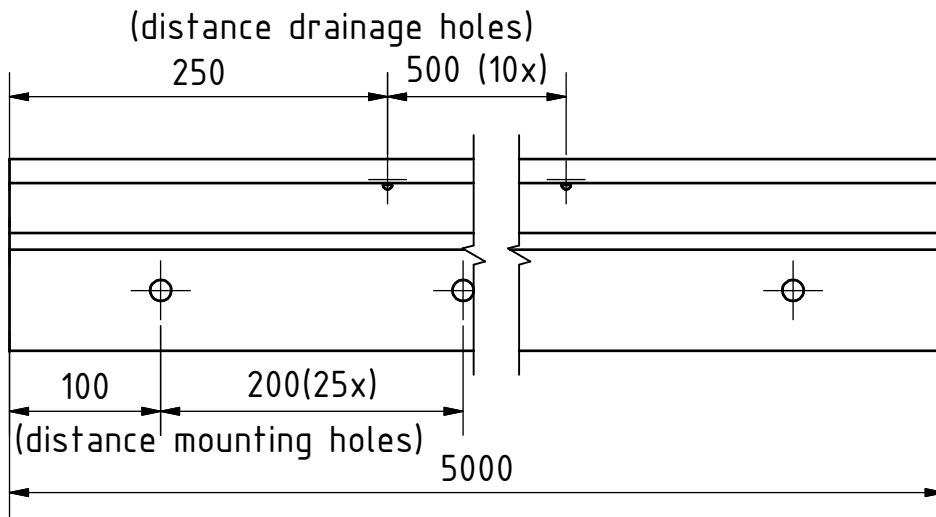

3D view

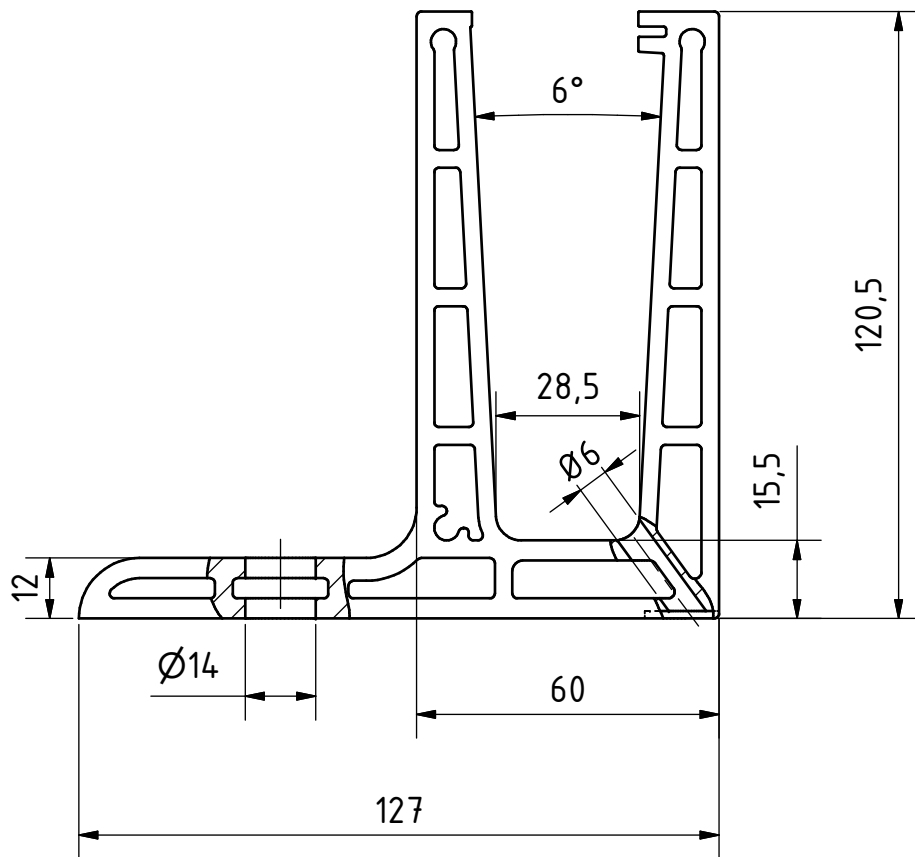
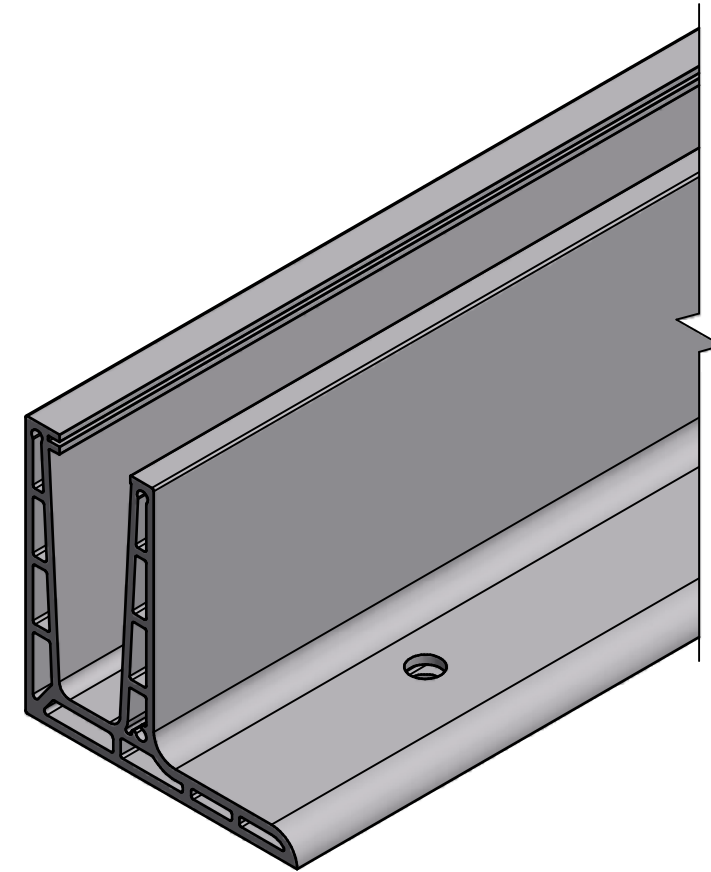

		Scale: 1 : 1,5	Weight: 38 kg		Rev.No.: 0									
		Material: EN AW-6063 T6			Finish: sample no ~18									
<small>THIS DRAWING IS PROPERTY OF Q-RAILING EUROPE GmbH & Co KG ALL RIGHTS RESERVED. It may not be submitted for perusal to third parties, either whole nor partly, unless granted. It is not permitted to alter this drawing unauthorised, in any way.</small>		Product line: Easy Glass Pro												
<table border="1"> <thead> <tr> <th></th> <th>Date</th> <th>Name</th> </tr> </thead> <tbody> <tr> <td>Drawn</td> <td>31.01.2014</td> <td>YPE</td> </tr> <tr> <td>Checked</td> <td>13.05.2014</td> <td>TRR</td> </tr> </tbody> </table>			Date	Name	Drawn	31.01.2014	YPE	Checked	13.05.2014	TRR	Description: Base Shoe Top F			
	Date	Name												
Drawn	31.01.2014	YPE												
Checked	13.05.2014	TRR												
Drawing no.: CD-16690950018				Sheet: 1 / 1 A4										

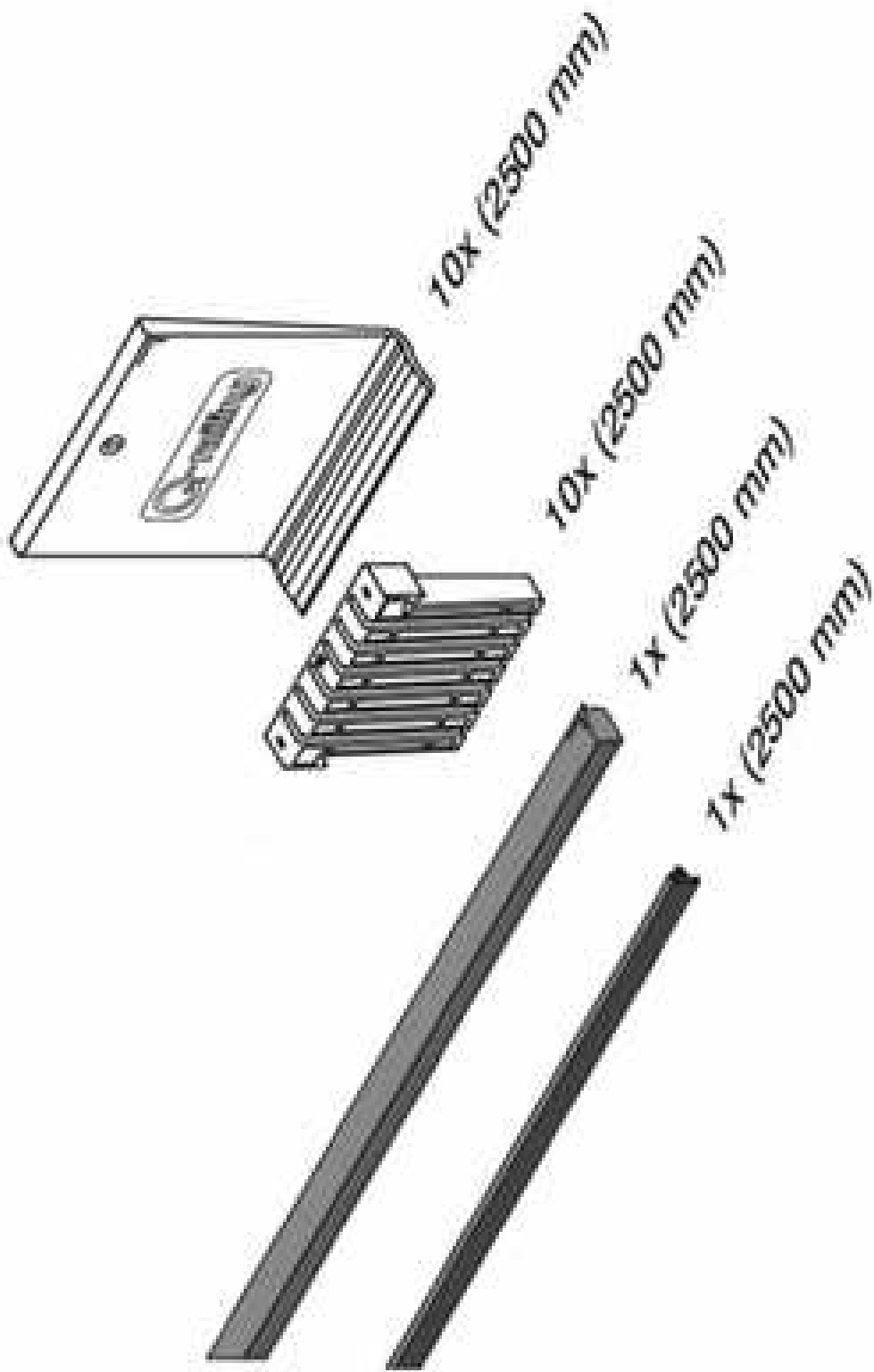

TEST REPORT

Lucideon Reference: 143646 (QT-31643/1/SL)/Ref. 1

Project Title: Testing of Q-railing Europe Glass Balustrade System to BS 6180:2011 - Easy Glass Pro-F Top Mount Adjustable

Client: Q-railing Europe GmbH & Co.KG
Marie-Curie-Strasse 8-14
Emmerich am Rhein
D-46446
Germany

For the Attention of: Mr Samuel Hanna

Author(s): Miss Lisa Cobden

Report Date: 29 August, 2014

Purchase Order No.: N/A

Work Location: Lucideon UK



Mr Dave Dix
Consultancy Team
Reviewer



Miss Lisa Cobden
Consultancy Team
Project Manager

CONTENTS

	Page
1 INTRODUCTION	3
2 TEST SAMPLES	3
3 TEST PROGRAMME	3
4 TEST METHOD	3
5 RESULTS	4
TABLES	5-6
PLATE	7
CHART	8

APPENDIX: Figures

LSC/LMP/N14TRE46
29.08.14

1 INTRODUCTION

Lucideon were commissioned by the client, Q-railing Europe GmbH and Co KG, to carry out load testing in accordance with BS 6180:2011 Barriers in and about buildings, to allow their balustrade system to be classified for use in accordance with the Code of Practice included within the standard.

The testing was carried out at Q-railing Europe GmbH and Co KG's facilities at 8-14 Marie-Curie Straße 46446 Emmerich am Rhein Germany.

This report summarises the test results obtained during the test programme and does not provide interpretation of those results.

2 TEST SAMPLES

The aluminium channel tested was designated as Easy Glass Pro-F Top Mount Adjustable. The system is shown in Figure 1.

The channel was installed by Q-railing personnel.

3 TEST PROGRAMME

A horizontal line load was applied to the aluminium channel with the following glass types installed:

- Laminated VSG Glass with 16.76 mm – size (w x h):1000 mm x 1100 mm.
- Laminated VSG Glass with 21.52 mm – size (w x h):1000 mm x 1100 mm.
- Monolithic ESG Glass 15 mm – size (w x h): 1000 mm x 1100 mm.
- Monolithic ESG Glass 19 mm – size (w x h): 1000 mm x 1100 mm.

4 TEST METHOD

The channel was bolted to the top of a concrete block, which was fixed to the floor of the test facility. The 1.0 m length of channel was bolted to the block at 200 mm centres by the client using the appropriate fixings (see Figure 2).

The appropriate thickness glass panel was fitted into the channel using the 'Adjustable Wedges' at four wedges per metre top and bottom (See Figures 1 and 3)

A horizontal imposed line load was applied to the glass at a height of 1.1 m above the datum level of the floor and the deflection measured at the top central point of the panel 1.1 m above the datum level of the floor. The load was applied via a hydraulic ram and the deflection measured using a linear voltage displacement transducer (see Plate 1).

5 RESULTS

The test was carried out in accordance with the guidance given in BS 6180 Barriers in and about buildings – Code of Practice. The standard states that the maximum allowable deflection for a free standing glass protective barrier panel is 25 mm.

Table 2 of BS 6180 Barriers in and about buildings – Code of Practice categorises parapets, barriers and balustrades for areas of use depending on the loads they have achieved under testing.

The loads achieved by the Q-railing Europe GmbH and Co KG glazing system tested under horizontal imposed line load to the maximum deflection of 25 mm are given in Table 1.

All figures quoted in Table 1 contain no safety factors and are direct loads as achieved by the system under test conditions.

Table 2 summarises the suitability of the tested systems in accordance with Table 2 of BS 6180:2011.

NOTE: The results given in this report apply only to the samples that have been tested.

END OF REPORT

Table 1: Summary of Performance of Q-railing Europe GmbH and Co. KG Balustrade System Tested under Horizontal Imposed Line Load

Base Rail	Glass	Imposed Line Load at 25 mm Deflection (kN/m)	Working Line Load for System (kN/m)	Deflection at Working Line Load for System (mm)
System	Laminated VSG Glass 16.76 mm	0.55	0.36	16.37
	Laminated VSG Glass 21.52 mm	0.89	0.74	21.02
	Monolithic ESG 19 mm	1.17	0.74	14.40
	Monolithic ESG 15 mm	0.88	0.74	21.06

Table 2: Summary of Suitability of Q-railing Europe Systems in Accordance with Table 2 of BS 6180:2011

Type of Occupancy for Part of the Building	Examples of Specific Use	Horizontal Uniformly Distributed Line Load (kN/m)	Easy Glass Pro-F Top Mount Adjustable			
			16.76 mm	21.52 mm	19 mm	15 mm
Domestic and residential activities	(i) all areas within or serving exclusively one single family dwelling including stairs, landings, etc but excluding external balconies and edges of roofs	0.36	✓	✓	✓	✓
	(ii) other residential, i.e. houses of multiple occupancy and balconies, including Juliette balconies and edges of roofs in single family dwellings	0.74	X	✓	✓	✓
Offices and work areas not included elsewhere, including storage areas	(iii) light access stairs and gangways not more than 600 mm wide	0.22	✓	✓	✓	✓
	(iv) light pedestrian traffic routes in industrial and storage buildings except designated escape routes	0.36	✓	✓	✓	✓
	(v) areas not susceptible to overcrowding in office and institutional buildings, also industrial and storage buildings except as given above	0.74	X	✓	✓	✓
Areas where people might congregate	(vi) areas having fixed seating within 530 mm of the barrier, balustrade or parapet	1.50	X	X	X	X

Type of Occupancy for Part of the Building	Examples of Specific Use	Horizontal Uniformly Distributed Line Load (kN/m)	Easy Glass Pro-F Top Mount Adjustable			
			16.76 mm	21.52 mm	19 mm	15 mm
Areas with tables or fixed seating	(vii) restaurants and bars	1.50	X	X	X	X
Areas without obstacles for moving people and not susceptible to overcrowding	(viii) stairs, landings corridors ramps	0.74	X	✓	✓	✓
	(ix) external balconies including Juliette balconies and edges of roofs; footways and pavements within building cartilage adjacent to basement/sunken areas	0.74	X	✓	✓	✓
Areas susceptible to overcrowding	(x) footways or pavements less than 3 m wide adjacent to sunken areas	1.50	X	X	X	X
	(xi) theatres, cinemas, discotheques, bars, auditoria, shopping malls, assembly areas, studios; footways or pavements greater than 3 m wide adjacent to sunken areas	3.00	X	X	X	X
	(xii) grandstands and stadia	(Note 1)	-	-	-	-
Retail areas	(xiii) all retail areas including public areas of banks/building societies or betting shops	1.50	X	X	X	X
Vehicular	(xiv) pedestrian areas in car parks, including stairs, landings, ramps, edges of internal floors, footways, edges of roofs	1.50 (Note 2)	X	X	X	X
	(xv) horizontal loads imposed by vehicles	(Note 2)	-	-	-	-

Note 1 – See requirements of the appropriate certifying authority

Note 2 – Clause 8.1.1 of BS 6180:2011 states that “glass should not be used for vehicle protection barriers”



Plate 1: Generic Test Arrangement

Chart 1: Load Versus Deflection Curves for Q-railing Easy Glass Pro F TopMount Adjustable

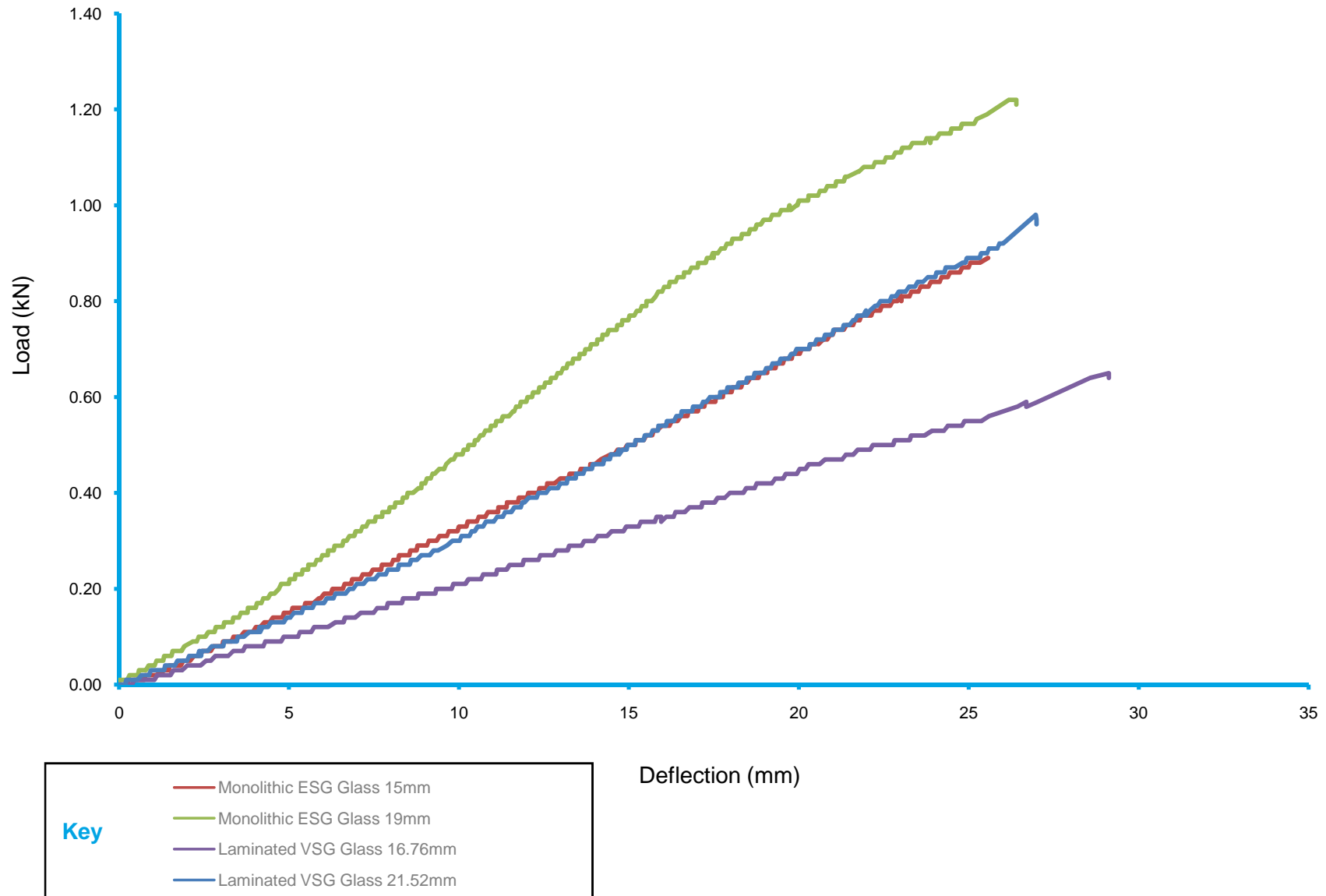

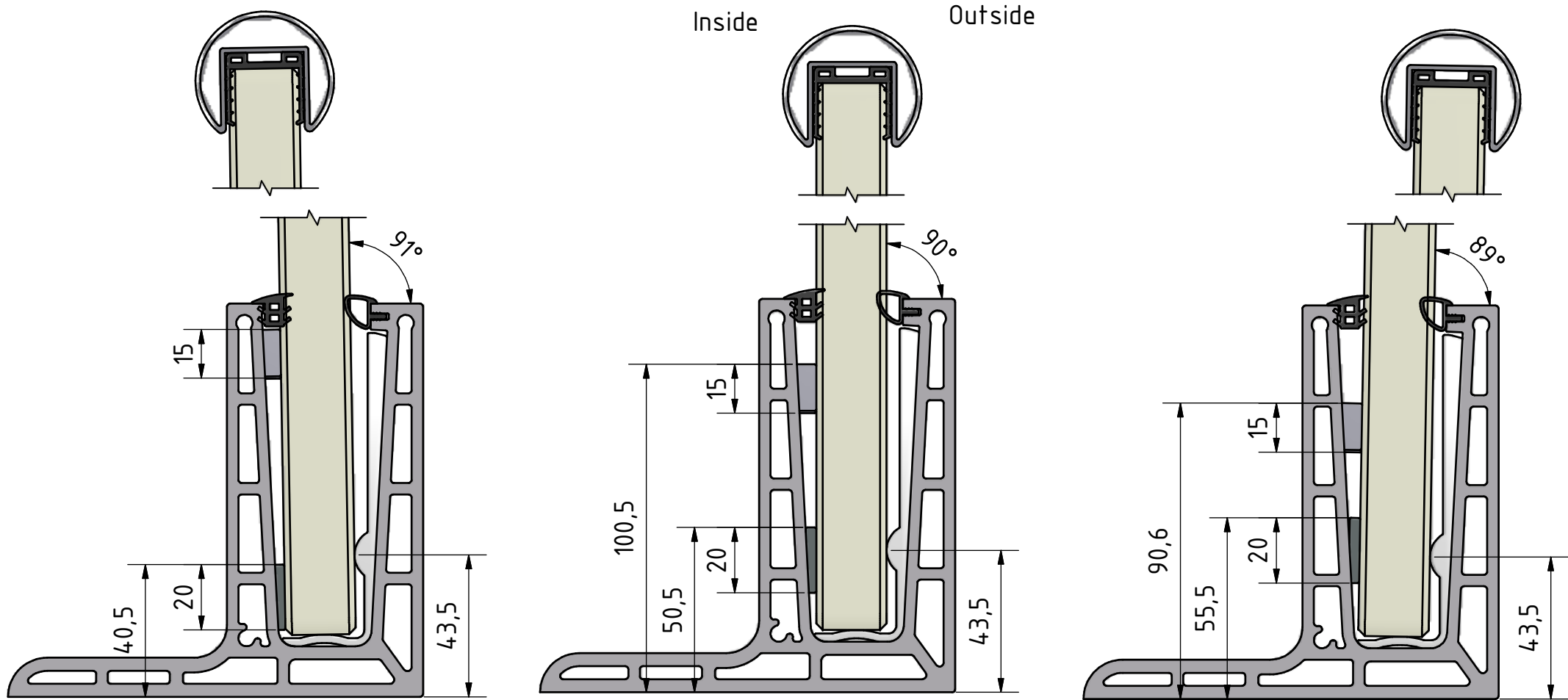

Inlay, Wedge top and Wedge bottom 4 per meter

		Scale: 1 : 1,5	Weight: N/A		Rev.No.:									
		Material:												
<small>THIS DRAWING IS PROPERTY OF Q-RAILING EUROPE GmbH & Co KG ALL RIGHTS RESERVED. It may not be submitted for perusal to third parties, either whole nor partly, unless granted. It is not permitted to alter this drawing unauthorised, in any way.</small>		Finish:												
<table border="1"> <thead> <tr> <th></th> <th>Date</th> <th>Name</th> </tr> </thead> <tbody> <tr> <td>Drawn</td> <td>23-8-2013</td> <td>GMK</td> </tr> <tr> <td>Checked</td> <td></td> <td></td> </tr> </tbody> </table>			Date	Name	Drawn	23-8-2013	GMK	Checked			Product line:			
	Date	Name												
Drawn	23-8-2013	GMK												
Checked														
General tolerance according DIN ISO 2768 - mK		Description:												
		Drawing no.:			Sheet:									
		<h1>Assy new profile</h1>			1 / 1									
					A4									

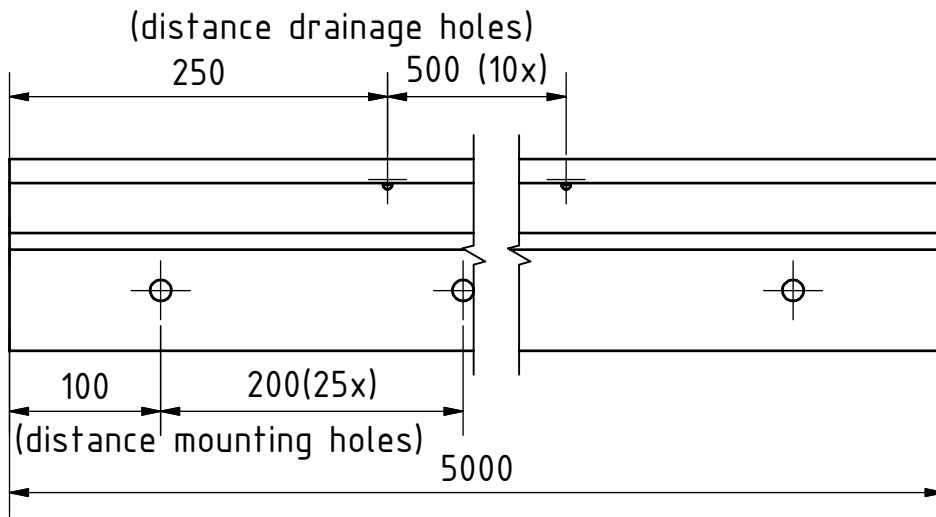

3D view

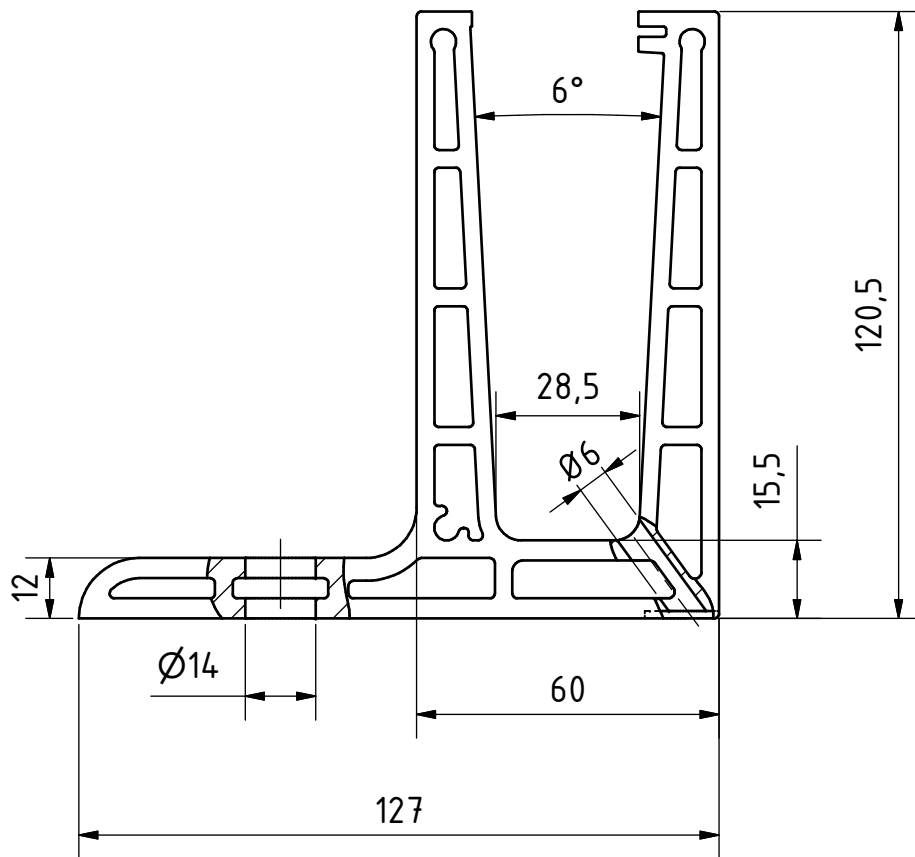
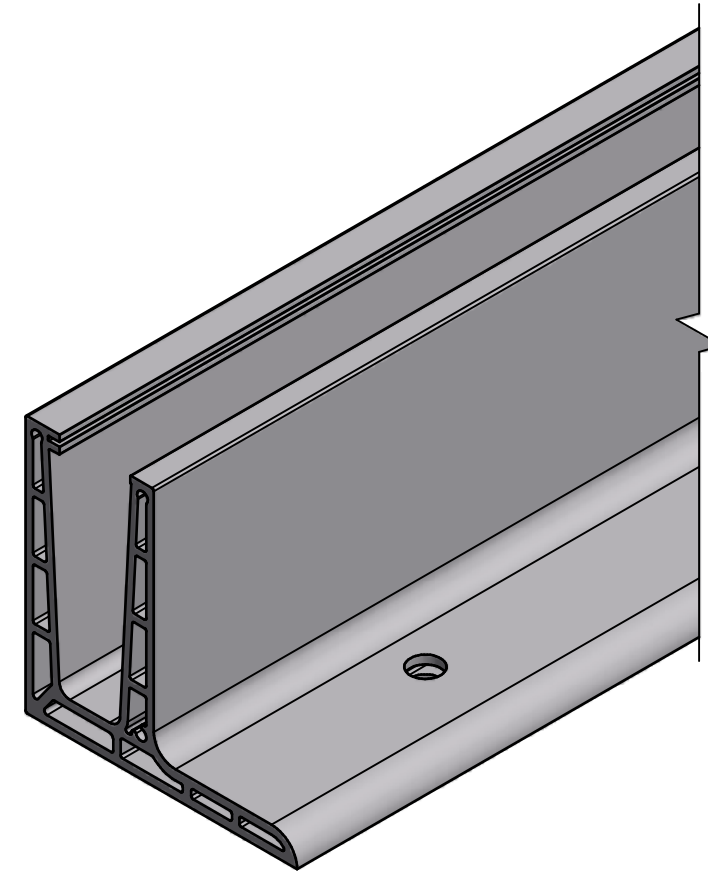

		Scale: 1 : 1,5	Weight: 38 kg		Rev.No.: 0									
		Material: EN AW-6063 T6		Finish: sample no ~18										
<small>THIS DRAWING IS PROPERTY OF Q-RAILING EUROPE GmbH & Co KG ALL RIGHTS RESERVED. It may not be submitted for perusal to third parties, either whole nor partly, unless granted. It is not permitted to alter this drawing unauthorised, in any way.</small>		Product line: Easy Glass Pro												
<table border="1"> <thead> <tr> <th></th> <th>Date</th> <th>Name</th> </tr> </thead> <tbody> <tr> <td>Drawn</td> <td>31.01.2014</td> <td>YPE</td> </tr> <tr> <td>Checked</td> <td>13.05.2014</td> <td>TRR</td> </tr> </tbody> </table>			Date	Name	Drawn	31.01.2014	YPE	Checked	13.05.2014	TRR	Description: Base Shoe Top F			
	Date	Name												
Drawn	31.01.2014	YPE												
Checked	13.05.2014	TRR												
Drawing no.: CD-16690950018				Sheet: 1 / 1										
				A4										

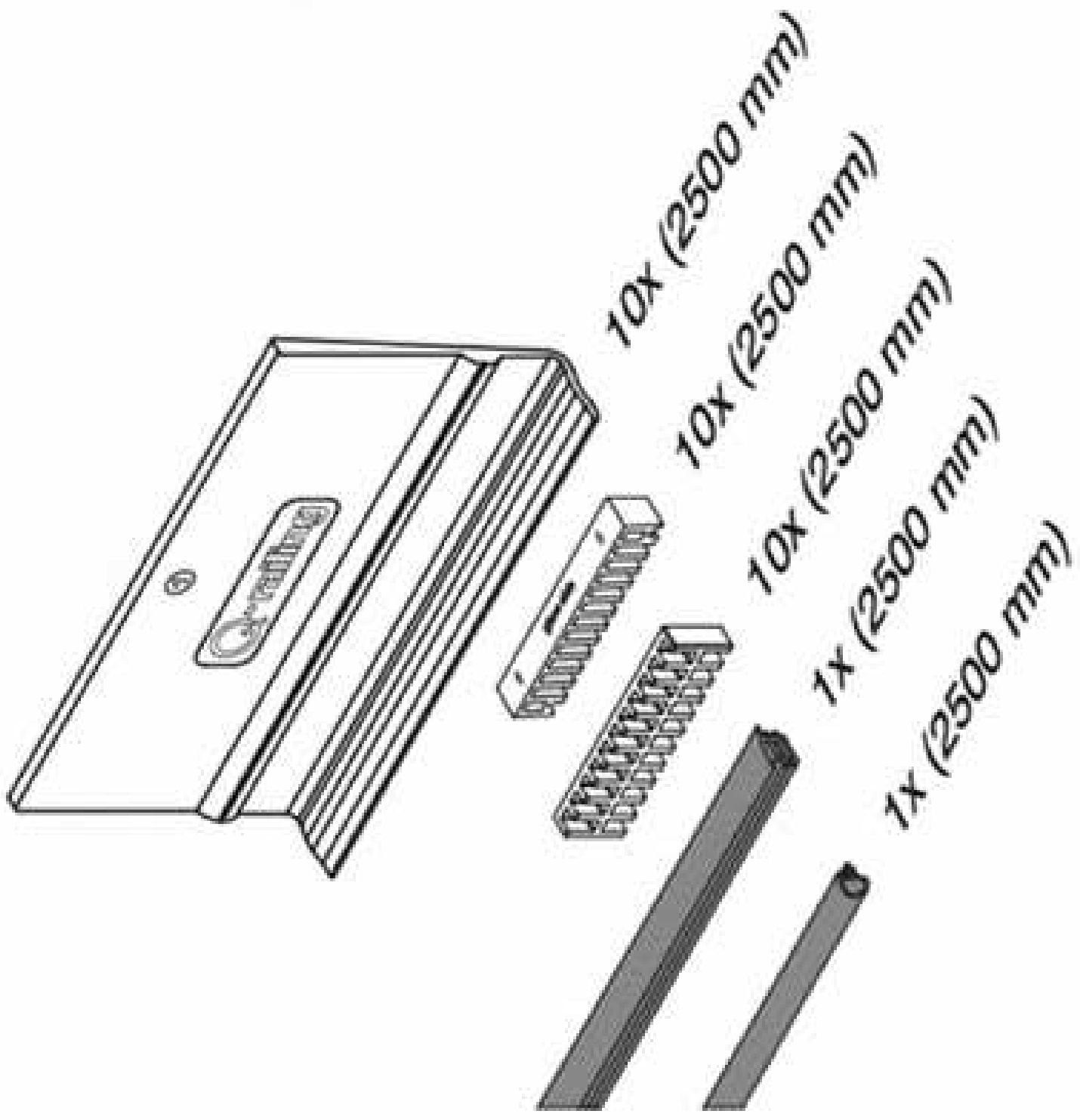

TEST REPORT

Lucideon Reference: 143646 (QT-31643/1/SL)/Ref. 2

Project Title: Testing of Q-railing Europe Glass Balustrade System to BS 6180:2011 - Easy Glass Pro-F Top Mount Adjustable 1200 mm Horizontal Line Load

Client: Q-railing Europe GmbH & Co.KG
Marie-Curie-Strasse 8-14
Emmerich am Rhein
D-46446
Germany

For the Attention of: Mr Samuel Hanna

Author(s): Miss Lisa Cobden

Report Date: 29 August, 2014

Purchase Order No.: N/A

Work Location: Lucideon UK



Mr Dave Dix
Consultancy Team
Reviewer



Miss Lisa Cobden
Consultancy Team
Project Manager

CONTENTS

	Page
1 INTRODUCTION	3
2 TEST SAMPLES	3
3 TEST PROGRAMME	3
4 TEST METHOD	3
5 RESULTS	4
TABLES	5-6
PLATE	7
CHART	8

APPENDIX: Figures

LSC/LMP/N14TRE47
29.08.14

1 INTRODUCTION

Lucideon were commissioned by the client, Q-railing Europe GmbH and Co KG, to carry out load testing based on that detailed in BS 6180:2011 Barriers in and about buildings. This was to allow their balustrade system to be classified for use in accordance with the Code of Practice included within the standard. The test method deviated from the standard such that the horizontal imposed line load was applied to the glass at a height of 1.2 m above the datum level of the floor in comparison to 1.1 m stated in the standard. Deflection of the glass panel was measured at the top central point and was also recorded at 1.2 m above the datum level of the floor.

The testing was carried out at Q-railing Europe GmbH and Co KG's facilities at 8-14 Marie-Curie Straße 46446 Emmerich am Rhein Germany.

This report summarises the test results obtained during the test programme and does not provide interpretation of those results.

2 TEST SAMPLES

The aluminium channel tested was designated as Easy Glass Pro-F Top Mount Adjustable. The system is shown in Figure 1.

The channel was installed by Q-railing personnel.

3 TEST PROGRAMME

A horizontal line load was applied to the aluminium channel with the following glass types installed:

- Laminated VSG Glass 21.52 mm – size (w x h): 1000 mm x 1200 mm.
- Monolithic ESG Glass 19 mm – size (w x h): 1000 mm x 1200 mm.
- Monolithic ESG Glass 15 mm – size (w x h): 1000 mm x 1200 mm.

4 TEST METHOD

The channel was bolted to the top of a concrete block, which was fixed to the floor of the test facility. The 1.0 m length of channel was bolted to the block at 200 mm centres by the client using the appropriate fixings (see Figure 2).

The appropriate thickness glass panel was fitted into the channel using the 'Adjustable Wedges' at four wedges per metre top and bottom (see Figures 1 and 3).

A horizontal imposed line load was applied to the glass at a height of 1.2 m above the datum level of the floor and the deflection measured at the top central point of the panel 1.2 m above the datum level of the floor. The load was applied via a hydraulic ram and the deflection measured using a linear voltage displacement transducer (see Plate 1).

5 RESULTS

The test was carried out in accordance with the guidance given in BS 6180 Barriers in and about buildings – Code of Practice. The standard states that the maximum allowable deflection for a free standing glass protective barrier panel is 25 mm.

Table 2 of BS 6180 Barriers in and about buildings – Code of Practice categorises parapets, barriers and balustrades for areas of use depending on the loads they have achieved under testing.

The loads achieved by the Q-railing Europe GmbH and Co KG glazing system tested under horizontal imposed line load to the maximum deflection of 25 mm are given in Table 1.

All figures quoted in Table 1 contain no safety factors and are direct loads as achieved by the system under test conditions.

Table 2 summarises the suitability of the tested systems in accordance with Table 2 of BS 6180:2011.

NOTE: The results given in this report apply only to the samples that have been tested.

END OF REPORT

Table 1: Summary of Performance of Q-railing Europe GmbH and Co KG Balustrade System Tested under Horizontal Imposed Line Load

Base Rail	Glass	Imposed Line Load at 25 mm Deflection (kN/m)	Working Line Load for System (kN/m)	Deflection at Working Line Load for System (mm)
System	Laminated VSG Glass 21.52 mm	0.65	0.36	14.73
	Monolithic ESG 19 mm	0.90	0.74	21.27
	Monolithic ESG 15 mm	0.52	0.36	19.06

Table 2: Summary of Suitability of Q-railing Europe Systems in Accordance with Table 2 of BS 6180:2011

Type of Occupancy for Part of the Building	Examples of Specific Use	Horizontal Uniformly Distributed Line Load (kN/m)	Easy Glass Pro-F Top Mount Adjustable		
			21.52 mm	19 mm	15 mm
Domestic and residential activities	(i) all areas within or serving exclusively one single family dwelling including stairs, landings, etc but excluding external balconies and edges of roofs	0.36	✓	✓	✓
	(ii) other residential, i.e. houses of multiple occupancy and balconies, including Juliette balconies and edges of roofs in single family dwellings	0.74	X	✓	X
Offices and work areas not included elsewhere, including storage areas	(iii) light access stairs and gangways not more than 600 mm wide	0.22	✓	✓	✓
	(iv) light pedestrian traffic routes in industrial and storage buildings except designated escape routes	0.36	✓	✓	✓
	(v) areas not susceptible to overcrowding in office and institutional buildings, also industrial and storage buildings except as given above	0.74	X	✓	X
Areas where people might congregate	(vi) areas having fixed seating within 530 mm of the barrier, balustrade or parapet	1.50	X	X	X
Areas with tables or fixed seating	(vii) restaurants and bars	1.50	X	X	X

Type of Occupancy for	Examples of Specific Use	Horizontal Uniformly	Easy Glass Pro-F Top Mount Adjustable		
Areas without obstacles for moving people and not susceptible to overcrowding	(viii) stairs, landings corridors ramps	0.74	X	✓	X
	(ix) external balconies including Juliette balconies and edges of roofs; footways and pavements within building cartilage adjacent to basement/sunken areas	0.74	X	✓	X
Areas susceptible to overcrowding	(x) footways or pavements less than 3 m wide adjacent to sunken areas	1.50	X	X	X
	(xi) theatres, cinemas, discotheques, bars, auditoria, shopping malls, assembly areas, studios; footways or pavements greater than 3 m wide adjacent to sunken areas	3.00	X	X	X
	(xii) grandstands and stadia	(Note 1)	-	-	-
Retail areas	(xiii) all retail areas including public areas of banks/building societies or betting shops	1.50	X	X	X
Vehicular	(xiv) pedestrian areas in car parks, including stairs, landings, ramps, edges of internal floors, footways, edges of roofs	1.50 (Note 2)	X	X	X
	(xv) horizontal loads imposed by vehicles	(Note 2)	-	-	-

Note 1 – See requirements of the appropriate certifying authority

Note 2 – Clause 8.1.1 of BS 6180:2011 states that “glass should not be used for vehicle protection barriers”



Plate 1: Generic Test Arrangement

Chart 1: Load Versus Deflection Curves for Q-railing Easy Glass Pro-F Top Mount Adjustable Line Load at 1200 mm

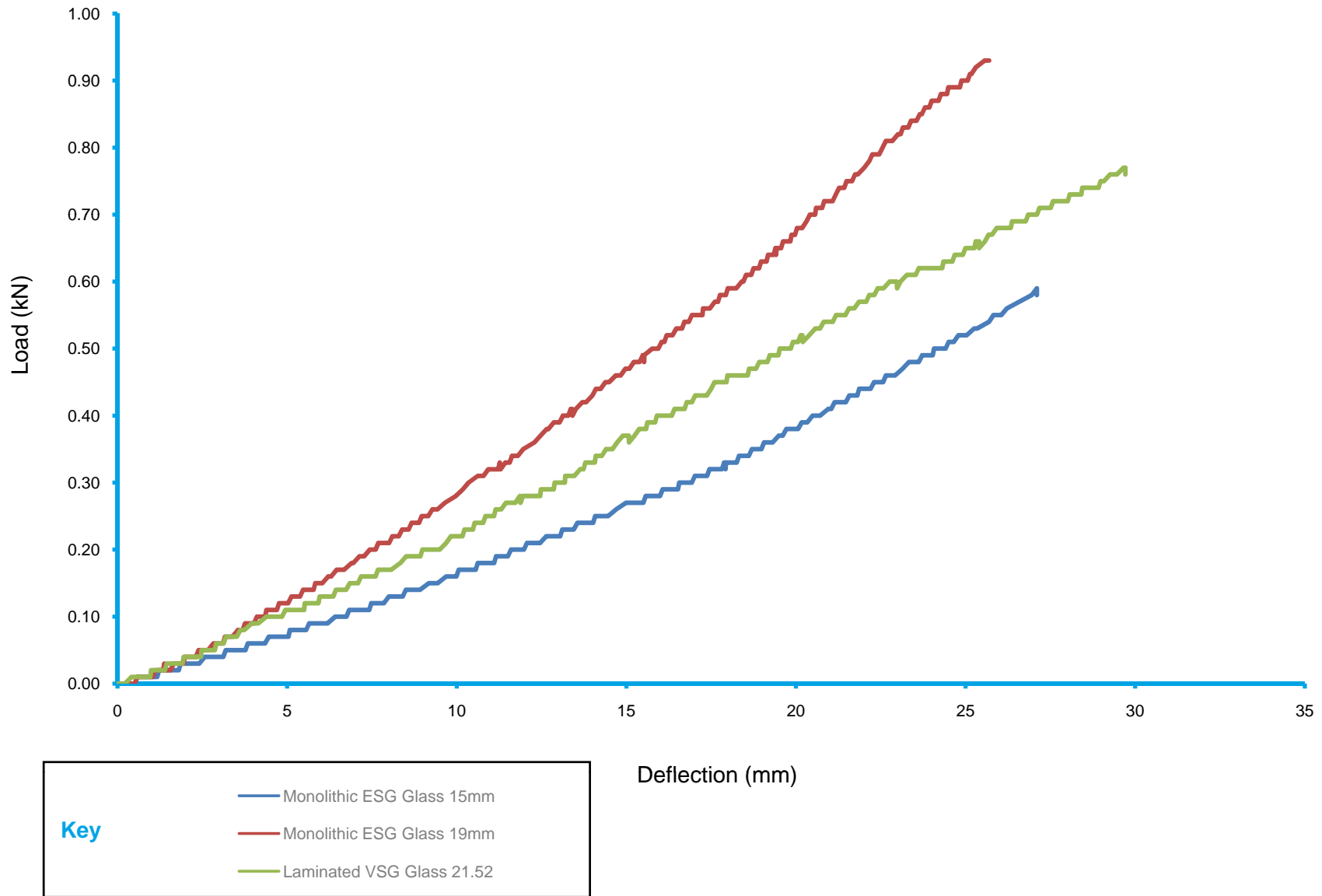

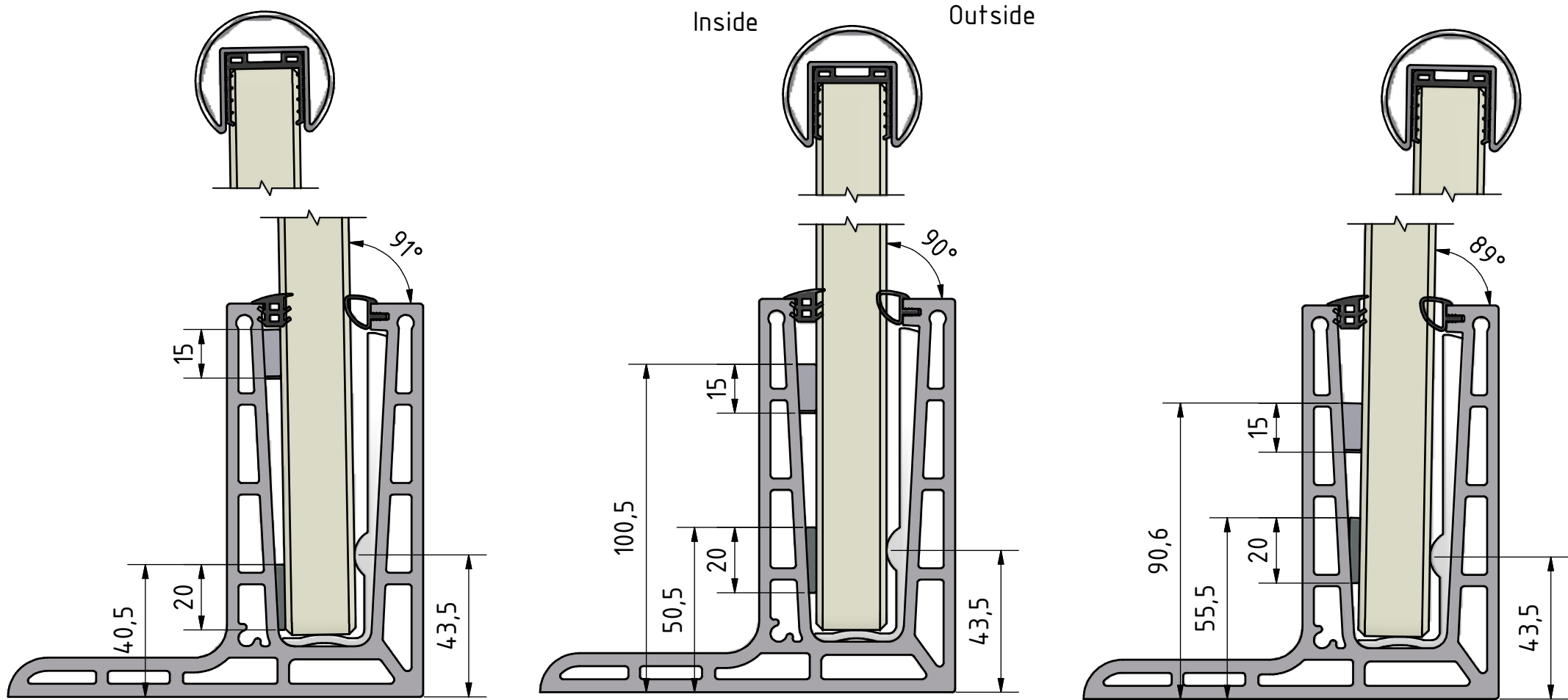

Inlay, Wedge top and Wedge bottom 4 per meter

		Scale: 1 : 1,5	Weight: N/A		Rev.No.:						
		Material:									
<small>THIS DRAWING IS PROPERTY OF Q-RAILING EUROPE GmbH & Co KG ALL RIGHTS RESERVED. It may not be submitted for perusal to third parties, either whole nor partly, unless granted. It is not permitted to alter this drawing unauthorised, in any way.</small>		Finish:									
<table border="1"> <thead> <tr> <th>Date</th> <th>Name</th> </tr> </thead> <tbody> <tr> <td>23-8-2013</td> <td>GMK</td> </tr> <tr> <td> </td> <td> </td> </tr> </tbody> </table>		Date	Name	23-8-2013	GMK			Product line:			
Date	Name										
23-8-2013	GMK										
General tolerance according DIN ISO 2768 - mK		Description:									
		Drawing no.:			Sheet:						
		<h1>Assy new profile</h1>			1 / 1						
					A4						

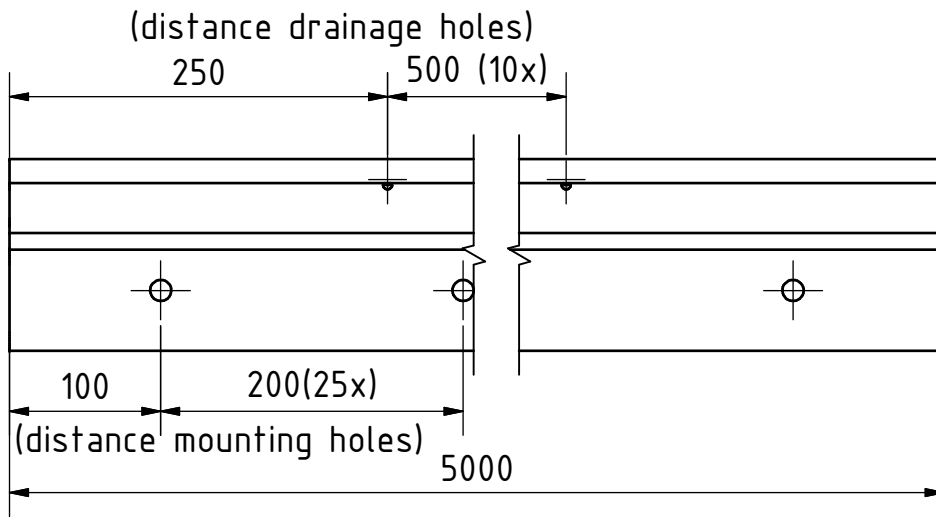

3D view

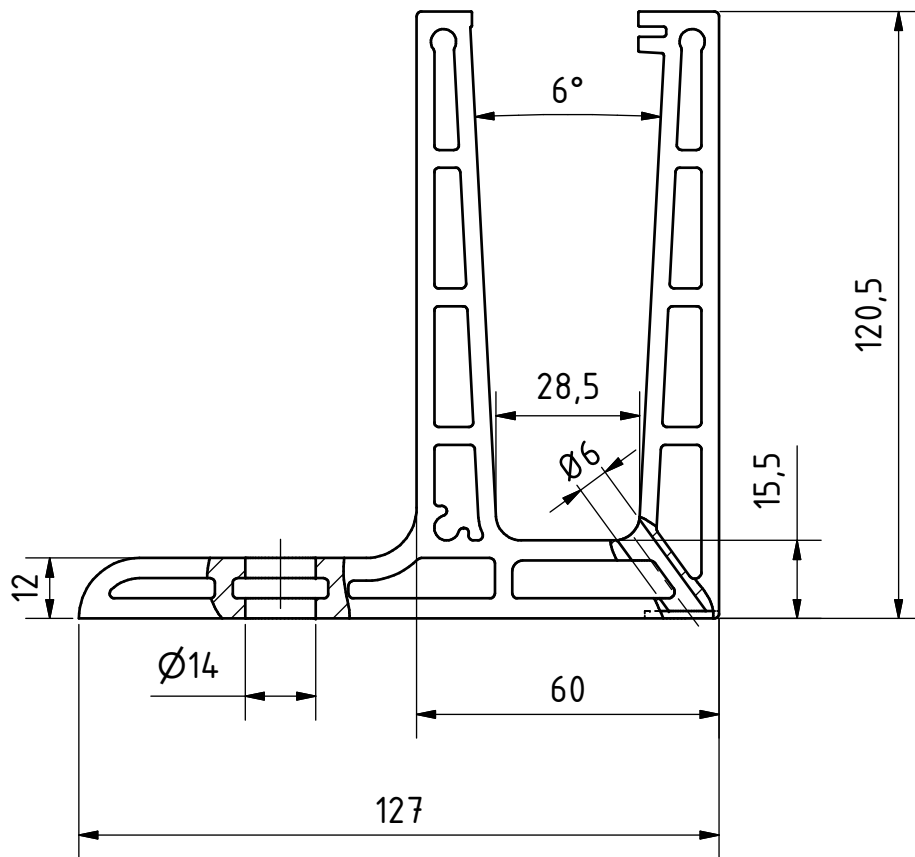
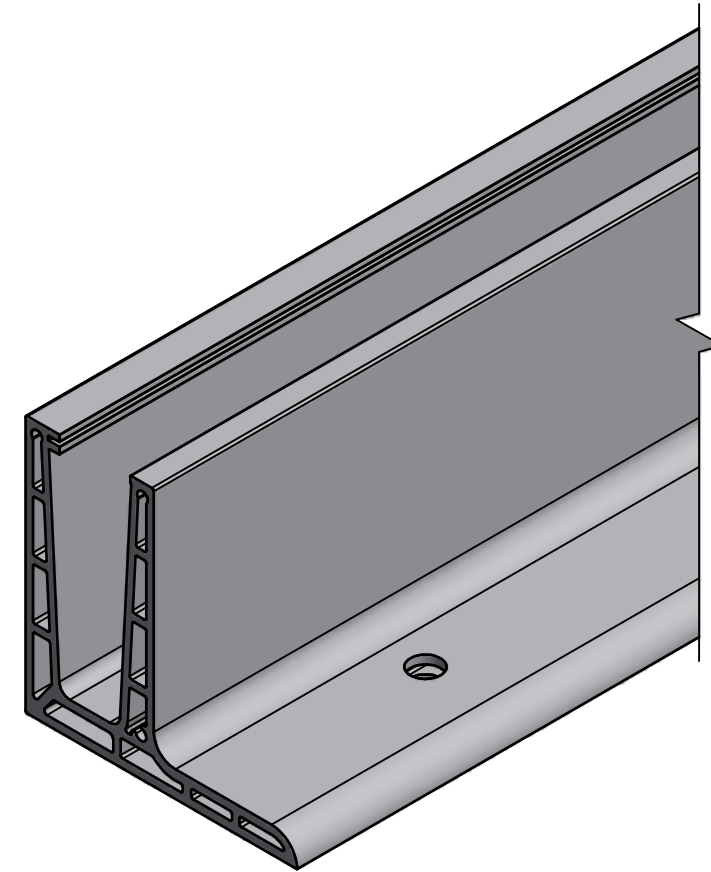

		Scale: 1 : 1,5	Weight: 38 kg		Rev.No.: 0									
		Material: EN AW-6063 T6	Finish: sample no ~18											
<small>THIS DRAWING IS PROPERTY OF Q-RAILING EUROPE GmbH & Co KG ALL RIGHTS RESERVED. It may not be submitted for perusal to third parties, either whole nor partly, unless granted. It is not permitted to alter this drawing unauthorised, in any way.</small>		Product line: Easy Glass Pro												
<table border="1"> <thead> <tr> <th></th> <th>Date</th> <th>Name</th> </tr> </thead> <tbody> <tr> <td>Drawn</td> <td>31.01.2014</td> <td>YPE</td> </tr> <tr> <td>Checked</td> <td>13.05.2014</td> <td>TRR</td> </tr> </tbody> </table>			Date	Name	Drawn	31.01.2014	YPE	Checked	13.05.2014	TRR	Description: Base Shoe Top F			
	Date	Name												
Drawn	31.01.2014	YPE												
Checked	13.05.2014	TRR												
Drawing no.: CD-16690950018				Sheet: 1 / 1 A4										

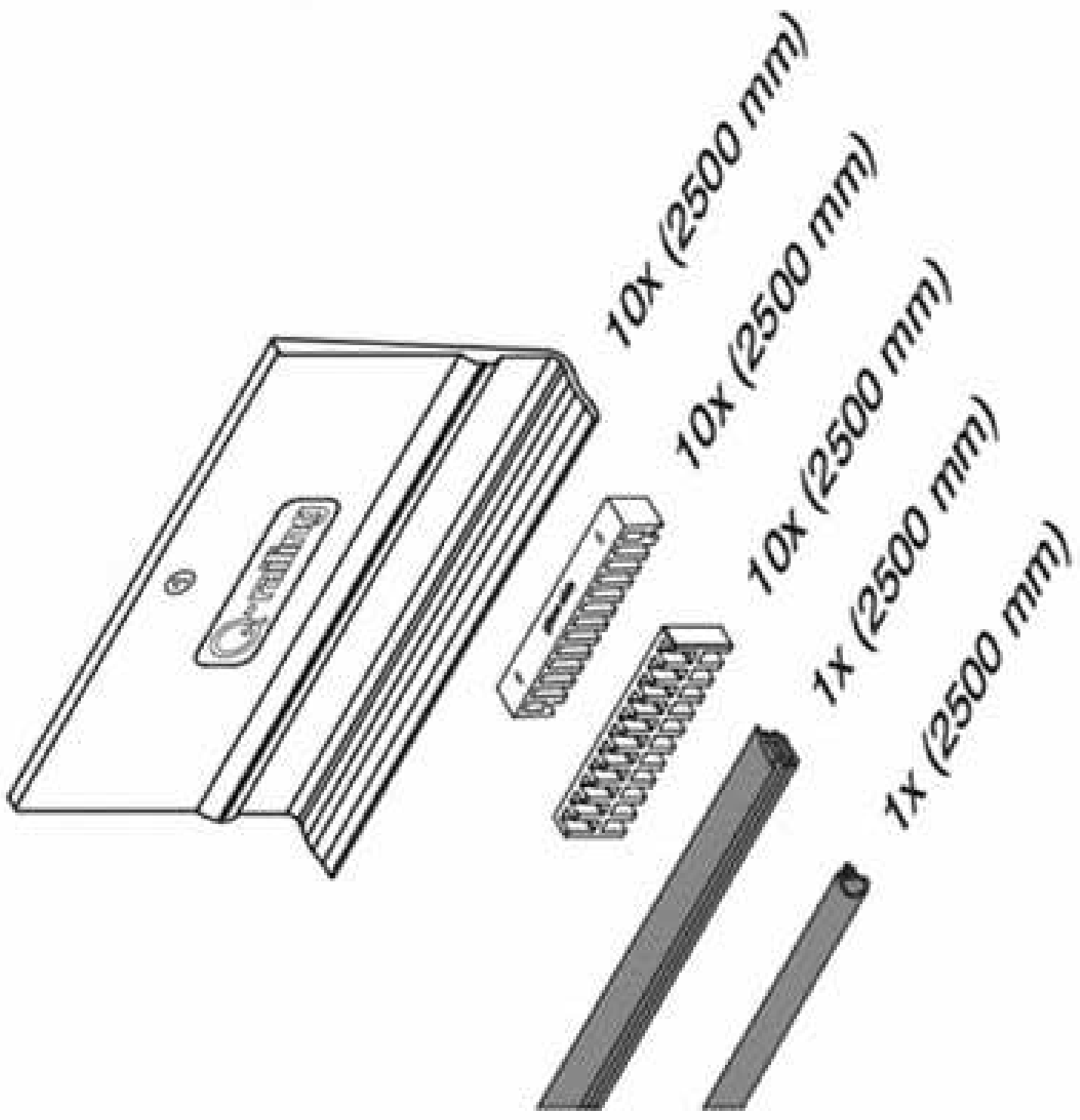

GOOD LUCK WITH
YOUR INSTALLATION!

VIEL ERFOLG MIT
IHRER MONTAGE!

SUCCES MET
DE INSTALLATIE!