



NATIONAL TEST REPORT (BS 6180:2011)

EASY GLASS[®] PRIME

TOP MONTAGE MOD.6960

Test Report 9633837

Part 1 of 4 Issue 3.

Q-Railing Europe GmbH & Co.KG

Introduction.

This report has been prepared by Gary Essam and Chris Rayment and relates to the activity detailed below:

Job/Registration Details	Client Details
Job number: 9633837 Job type: Testing Start Date: 30/07/2018 Test type: Type test Sample ID: Not applicable Registration: KM 656489 Scheme: BS 6180:2011 Protocol: PP937 Scheme Manager: Peter Rossington	Q-Railing Europe GmbH & Co.KG Marie-Curie-Strasse 8-14 Emmerich am Rhein 46446 Germany

The report has been approved for issue by Mark Manito – Team Manager

Approved For Issue	
	Issue Date: 24 September 2018

Objectives.

Type testing for product certification

Product Scope.

Balustrade system

Report Summary.

The balustrade system met the requirements or parts thereof of the Specification against which assessments were made

Issue 3 of this report supersedes all previous issues. The amendments on page 10 giving rise to this issue can be ascertained by contacting the authorising signatory.

Test Samples.

Sample Id	Description
1	Easy Glass Prime Top

Test Requirements.

BS 6180:2011 clauses 6.3.1 and 6.4.1 only - Barriers in and about buildings - Code of practice

Clause	Requirements
6	DESIGN CRITERIA
6.3	Loading
6.3.1	General N/As
6.4	Deflection
6.4.1	Barriers for the protection of people N/As
Results Tables	Actual test results <i>See Table A - BS 6180:2011</i>

Summary of Test Comments.

Clause	Comments
6.3.1 & 6.4.1	<p>BS 6180:2011 is a code of practice and the loaded deflections of barrier systems are given as recommendations only.</p> <p>The Structural Use of Glass in Buildings (Second Edition), February 2014, O'Regan, C., The Institution of Structural Engineers states "It must be noted that BS 6180 is a guideline and as such it is ultimately up to the designer to determine acceptable deflection limits on the balustrade under consideration."</p> <p>Further, the tables for summaries for suitability on pages 11 to 14 are given for indication only</p> <p>The testing was supervised at the Emmerich am Rhein site of Q-Railing from 31 July 2018 to 02 August 2018</p>

Glossary of Terms.

PASS: Complies. Tested by BSI engineers at BSI laboratories.

PASS1: Complies. Witnessed by BSI engineers in manufacturers laboratory.

PASS2: Complies. Tests carried out by third party lab; results accepted by BSI.

PASS*: Report resulted in uncertainty and states that Compliance is more probable than non-compliance.

FAIL: Non compliance – Product does not meet the requirements of this clause.

FAIL*: Report resulted in uncertainty and states that Non-compliance is more probable than compliance.

N/A: Not applicable to design under consideration.

N/T: Not tested due to similarity to previously tested item; reference earlier test report.

Conditions of Issue.

This Test Report is issued subject to the conditions stated in current issue of 'BSI Terms of Service'. The results contained herein apply only to the particular sample(s) tested and to the specific tests carried out, as detailed in this Test Report. The issuing of this Test Report does not indicate any measure of Approval, Certification, Supervision, Control or Surveillance by BSI of any product. No extract, abridgement or abstraction from a Test Report may be published or used to advertise a product without the written consent of BSI, who reserve the absolute right to agree or reject all or any of the details of any items or publicity for which consent may be sought.

Should you wish to speak with BSI in relation to this report, please contact Customer Services on +44 (0)8450 80 9000.

BSI
Kitemark House
Maylands Avenue
Hemel Hempstead
Hertfordshire
HP2 4SQ

Table A - BS 6180:2011

Test Results.

CLAUSE

6 DESIGN CRITERIA

6.3 Loading

6.3.1 General

Minimum horizontal imposed loads appropriate to the design of parapets, barriers, balustrades and other elements of structure intended to retain, stop or guide people, should be determined in accordance with Table 2 [of BS 6180:2011], which recommends a uniformly distributed line load for the barrier and a uniformly distributed and point load applied to the infill. These are not additive and should be considered as three separate load cases, all loads being determined according to the type of occupancy which reflects the possible in-service conditions.

Horizontal uniformly distributed line loads should be applied at the design height as presented in Table 1 [of BS 6180:2011] or at the design level 1100mm for barriers higher than the design height.

Uniformly distributed load should be applied at the area below the design height.

Point load should be applied at the most onerous point anywhere on the barrier structure.

6.4 Deflection

6.4.1 Barriers for the protection of people

Barriers for the protection of people should be of adequate strength and stiffness to sustain the applied loads given in Table 2 [of BS 6180:2011]. In addition, a barrier that is structurally safe should not possess sufficient flexibility to alarm building users when subject to normal service conditions. Therefore, for serviceability considerations, the limiting condition for deflection appropriate for a barrier for the protection of people is that the total horizontal displacement of the barrier at any point from its original unloaded position should not exceed the deflection limits determined from the relevant structural design code (where applicable) for the material used, or 25 mm, whichever is the smaller.

Where the infill of a barrier is subjected to imposed loads given in Table 2 [of BS 6180:2011], or if appropriate, other calculated design loads, the displacement of any point of the barrier should not exceed $L/65$ or 25 mm, whichever is the smaller where L is the given in **8.3**, **8.4** or defined in **8.5** [of BS 6180:2011]. A suitable fracture load, factored by a minimum partial safety factor of 4.0 (as recommended in BS 4592-0) should be obtained from the material manufacturer when considering glass barrier design.

Test Results (Continued).

Table 2 Minimum horizontal imposed loads for parapets, barriers and balustrades

Type of occupancy for part of the building or structure	Examples of specific use	Horizontal uniformly distributed line load (kN/m)	Uniformly distributed load applied to the infill (kN/m²)	A point load applied to part of the infill (kN)
Domestic and residential activities	(i) All areas within or serving exclusively one single family dwelling including stairs, landings, etc. but excluding external balconies and edges of roofs	0.36	0.5	0.25
	(ii) Other residential, i.e. houses of multiple occupancy and balconies, including Juliette balconies and edges of roofs in single family dwellings	0.74	1.0	0.5
Offices and work areas not included elsewhere, including storage areas	(iii) Light access stairs and gangways not more than 600 mm wide	0.22	-	-
	(iv) Light pedestrian traffic routes in industrial and storage buildings except designated escape routes	0.36	0.5	0.25
	(v) Areas not susceptible to overcrowding in office and institutional buildings, also industrial and storage buildings except as given above	0.74	1.0	0.5
Areas where people might congregate	(vi) Areas having fixed seating within 530 mm of the barrier, balustrade or parapet	1.5	1.5	1.5
Areas with tables or fixed seatings	(vii) Restaurants and bars	1.5	1.5	1.5

Test Results (Continued).

Table 2 Minimum horizontal imposed loads for parapets, barriers and balustrades (Continued)

Type of occupancy for part of the building or structure	Examples of specific use	Horizontal uniformly distributed line load (kN/m)	Uniformly distributed load applied to the infill (kN/m ²)	A point load applied to part of the infill (kN)
Areas without obstacles for moving people and not susceptible to overcrowding	(viii) Stairs, landings, corridors, ramps	0.74	1.0	0.5
	(ix) External balconies including Juliette balconies and edges of roofs. Footways and pavements within building curtilage adjacent to basement/sunken areas	0.74	1.0	0.5
Areas susceptible to overcrowding	(x) Footways or pavements less than 3 m wide adjacent to sunken areas	1.5	1.5	1.5
	(xi) Theatres, cinemas, discotheques, bars, auditoria, shopping malls, assembly areas, studio. Footways or pavements greater than 3 m wide adjacent to sunken areas.	3.0	1.5	1.5
	(xii) Grandstands and stadia ^{A)}	-	-	-
Retail areas	(xiii) All retail areas including public areas of banks/building societies or betting shops	1.5	1.5	1.5
Vehicular	(xiv) Pedestrian areas in car parks, including stairs, landings, ramps, edges or internal floors, footways, edges of roofs	1.5	1.5	1.5
	(xv) Horizontal loads imposed by vehicles ^{B)}	-	-	-

A) See requirements of the appropriate certifying authority

B) See Annex A

Test Results (Continued).

TEST METHODS

A single section of each size of balustrade system was bolted to a 3.2m x 0.5m x 0.5m concrete block which, in turn, was bolted to the concrete floor of the testing facility.

Horizontal uniformly distributed line loads

The horizontal uniformly distributed line loads were applied to the upper edge of the glass using a hand operated hydraulic cylinder through a calibrated load cell and display unit system to a 0.9m long aluminium beam to spread the load across the loading level of the glass panel. The assemblies were tested without handrails.

The deflection measurements of the upper edge of the glass were taken from a fixed datum point at the same level as the application of the load using a calibrated digital indicator.



Typical arrangement for application of horizontal uniformly distributed line loading assembly

Uniformly distributed load applied to the infill

The uniformly distributed loads were not applied to the test samples as the glass panels were not considered to be infills.

Point load applied to part of the infill

The point loads were not applied to the test samples as the glass panels were not considered to be infills.

Test Results (Continued).

TEST METHODS (Continued)

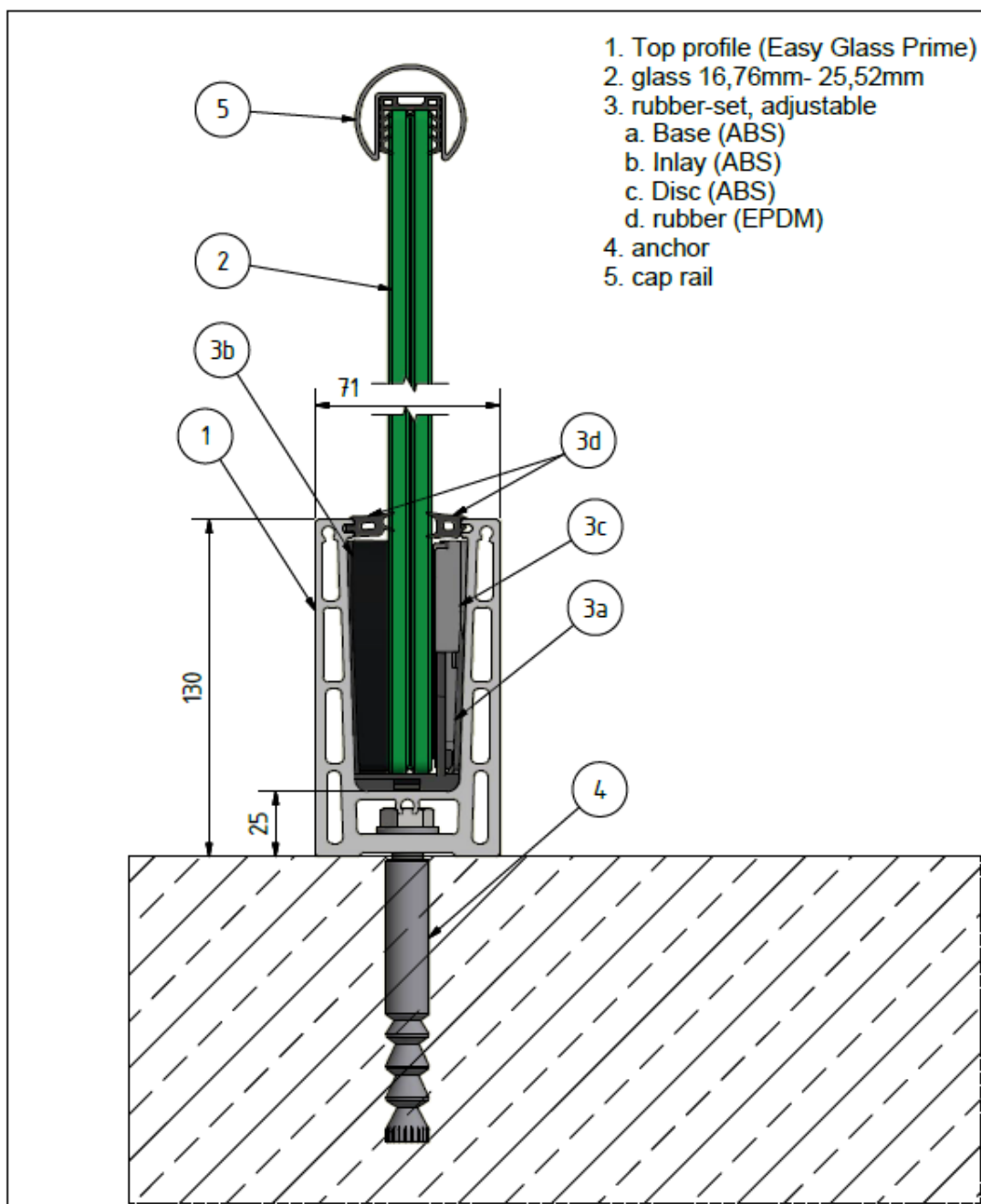

Easy Glass Prime Top assembly drawing (tested without handrail)

Test Results (Continued).

SUMMARY OF TESTING

Horizontal uniformly distributed line loads

Reference	Glass type	Glass size (mm x mm)	Loading and deflection height (mm)	Number of discs used	0.36 kN/m line load deflection (mm)	0.74 kN/m line load deflection (mm)	1.50 kN/m line load deflection (mm)	25mm equivalent line load (kN/m) (for information)	Comments
A	17.89mm Sentry	1200 x 1000	1100	4	8.29	18.07	-	1.00	
B	17.89mm Sentry	1200 x 1000	1200	4	10.27	22.45	-	0.81	
C	19mm mono	1200 x 1000	1100	4	7.04	15.19	-	1.18	
D	19mm mono	1200 x 1000	1200	4	8.61	18.69	-	0.97	
E	21.52mm PVB	1100 x 1000	1100	4	10.27	23.57	-	0.78	
F	21.25mm Sentry	1200 x 1000	1000	4	4.06	8.89	20.56	1.77	
G	21.25mm Sentry	1200 x 1000	1100	4	5.18	11.95	-	1.40	
H	21.25mm Sentry	1200 x 1000	1200	4	6.98	15.54	-	1.13	
I	21.25mm Sentry	1200 x 1000	1100	5	5.21	11.08	23.57	- ¹⁾	
J	21.25mm PVB	1200 x 1000	1200	5	10.07	24.35	-	- ¹⁾	

Notes:

1) Deflection not recorded

Test Results (Continued).

SUMMARY OF SUITABILITY OF BARRIER SYSTEMS

Type of occupancy for part of the building or structure	Examples of specific use	Horizontal uniformly distributed line load (kN/m)	Reference										
			A	B	C	D	E	F	G	H	I	J	
Domestic and residential activities	(i) All areas within or serving exclusively one single family dwelling including stairs, landings, etc. but excluding external balconies and edges of roofs	0.36	✓	✓	✓	✓	✓	✓	✓	✓	✓	✓	✓
	(ii) Other residential, i.e. houses of multiple occupancy and balconies, including Juliette balconies and edges of roofs in single family dwellings	0.74	✓	✓	✓	✓	✓	✓	✓	✓	✓	✓	✓
Offices and work areas not included elsewhere, including storage areas	(iii) Light access stairs and gangways not more than 600 mm wide	0.22	✓	✓	✓	✓	✓	✓	✓	✓	✓	✓	✓
	(iv) Light pedestrian traffic routes in industrial and storage buildings except designated escape routes	0.36	✓	✓	✓	✓	✓	✓	✓	✓	✓	✓	✓
	(v) Areas not susceptible to overcrowding in office and institutional buildings, also industrial and storage buildings except as given above	0.74	✓	✓	✓	✓	✓	✓	✓	✓	✓	✓	✓
Areas where people might congregate	(vi) Areas having fixed seating within 530 mm of the barrier, balustrade or parapet	1.5	X	X	X	X	X	✓	X	X	✓	X	
Areas with tables or fixed seatings	(vii) Restaurants and bars	1.5	X	X	X	X	X	✓	X	X	✓	X	

Test Results (Continued).

SUMMARY OF SUITABILITY OF BARRIER SYSTEMS (Continued)

Type of occupancy for part of the building or structure	Examples of specific use	Horizontal uniformly distributed line load (kN/m)	Reference									
			A	B	C	D	E	F	G	H	I	J
Areas without obstacles for moving people and not susceptible to overcrowding	(viii) Stairs, landings, corridors, ramps 0.74	0.74	✓	✓	✓	✓	✓	✓	✓	✓	✓	✓
	(ix) External balconies including Juliette balconies and edges of roofs. Footways and pavements within building curtilage adjacent to basement/sunken areas	0.74	✓	✓	✓	✓	✓	✓	✓	✓	✓	✓
Areas susceptible to overcrowding	(x) Footways or pavements less than 3 m wide adjacent to sunken areas	1.5	X	X	X	X	X	✓	X	X	✓	X
	(xi) Theatres, cinemas, discotheques, bars, auditoria, shopping malls, assembly areas, studio. Footways or pavements greater than 3 m wide adjacent to sunken areas.	3.0	X	X	X	X	X	X	X	X	X	X
	(xii) Grandstands and stadia ^{A)}	-	-	-	-	-	-	-	-	-	-	-
Retail areas	(xiii) All retail areas including public areas of banks/building societies or betting shops	1.5	X	X	X	X	X	✓	X	X	✓	X
Vehicular	(xiv) Pedestrian areas in car parks, including stairs, landings, ramps, edges or internal floors, footways, edges of roofs	1.5	X	X	X	X	X	✓	X	X	✓	X
	(xv) Horizontal loads imposed by vehicles ^{B)}	-	-	-	-	-	-	-	-	-	-	-

*** End of Report ***



GOOD LUCK WITH
YOUR INSTALLATION!

VIEL ERFOLG MIT
IHRER MONTAGE!

SUCCES MET
DE INSTALLATIE!